

# DPM-100 Modbus® Display Instruction Manual



**Modbus Display**

- Modbus® RTU Master, Slave, or Snooper Mode
- Poll and Display up to 16 Process Variables
- Large 6-Digit Dual-Line Display, Red LEDs, Sunlight Readable
- 32-Point, Square Root, or Exponential Linearization
- Addition, Difference, Average, Multiplication, Division, Min, Max, Weighted Average, Ratio, Concentration, & More
- Type 4X, NEMA 4X, IP65 Front
- Input Power Options Include 85-265 VAC or 12-24 VDC
- 2 or 4 Relays + 4-20 mA Output Options
- Multi-Pump Alternation Control
- Free USB Programming Software & Cable\*

\* Meter powered over USB for configuration only. Scanner will not read values from connected device while powered via USB connection.

## Disclaimer

The information contained in this document is subject to change without notice. BinMaster makes no representations or warranties with respect to the contents hereof; and specifically disclaim any implied warranties of merchantability or fitness for a particular purpose.



*Read complete instructions prior to installation and operation of the scanner.*



*Risk of electric shock or personal injury. Hazardous voltages exist within enclosure. Installation and service should be performed only by trained service personnel.*



*This product is not recommended for life support applications or applications where malfunctioning could result in personal injury or property loss. Anyone using this product for such applications does so at his/her own risk. BinMaster shall not be held liable for damages resulting from such improper use.*

## Limited Warranty

BinMaster warrants this product against defects in material or workmanship for the specified period under *Specifications* from the date of shipment from the factory. BinMaster's liability under this limited warranty shall not exceed the purchase value, repair, or replacement of the defective unit.

## Registered Trademarks

Modbus® is a Registered Trademark of Schneider Automation Inc. All other trademarks mentioned in this document are the property of their respective owners.

© 2018 BinMaster. All rights reserved.

[www.binmaster.com](http://www.binmaster.com)

# Table of Contents

Table of Contents	3	Slave Mode (SLAVE)	28
Table of Figures	4	<b>Setting Up the Scanner (SETUP)</b>	<b>29</b>
Introduction	5	Setting Up the Process Variables (PVs) (PV SETUP)	30
Ordering Information	6	Setting the Display Decimal Point (d, 5P.dP)	30
Specifications	7	Setting the Float Decimal Point (FLot.dP)	30
Operating Modes	7	Scaling the PV Display Values (SCALE)	31
Master & Snooper Settings	7	Scale Menu	31
PV Settings	7	<b>Setting Up the Displays (d5PLAY SETUP)</b>	<b>32</b>
Display Settings	7	Line 1 Parameters (LINE 1 d5PLAY)	32
Math Functions	8	Line 2 Parameters (LINE 2 d5PLAY)	32
Serial Communications	8	Display Intensity (d- INTY)	32
General	8	Display Line 1 Menu (LINE 1 d5PLAY)	33
Relays	9	Display Line 2 Menu (LINE 2 d5PLAY)	34
Isolated 4-20 mA Transmitter Output	9	Setting the Tags (TAG) & Units (UNITS)	35
MeterView Pro	9	Application Example 1	35
Compliance Information	10	Application Example 2	38
Safety	10	<b>Setting the Relay Operation (RELAY)</b>	<b>39</b>
Electromagnetic Compatibility	10	Relay Setup Menu (RELAY SETUP)	39
Safety Information	11	Setting the Relay Action (RelAct)	40
Installation	11	Programming Set (SET) & Reset (RST) Points	40
Unpacking	11	Setting Fail-Safe Operation (FRILSF)	40
Panel Mounting	11	Programming Time Delay (dELAY)	40
Mounting Dimensions	12	Relay Action for Communications Break (brERR)	41
Connections	13	<b>Relay and Alarm Operation Diagrams</b>	<b>41</b>
Connectors Labeling	13	High Alarm Operation (Set > Reset)	41
Power Connections	13	Low Alarm Operation (Set < Reset)	41
Serial Communications Connection	14	High Alarm with Fail-Safe Operation (Set > Reset)	42
Serial Communications Connections Table	15	Low Alarm with Fail-Safe Operation (Set < Reset)	42
F4 Digital Input Connections	15	Pump Alternation Control Operation	42
Relay Connections	16	Relay Sampling Operation	43
Switching Inductive Loads	16	Relay Operation After Communications Break	43
4-20 mA Output Connections	17	Time Delay Operation	44
Analog Output Transmitter Power Supply	17	<b>Relay Operation Details</b>	<b>45</b>
External Relay, Analog Output, & Digital I/O Connections	17	Overview	45
Interlock Relay Feature	17	Relays Auto Initialization	45
Setup and Programming	18	Fail-Safe Operation (FRILSF)	45
Overview	18	Front Panel LEDs	45
Front Panel Buttons and Status LED		Latching and Non-Latching Relay Operation	46
Indicators	18	Non-Latching Relay (RelAct)	46
Display Functions & Messages	19	Non-Latching Relay (RelAct)	46
ScanView Software	22	Latching Relay (LRelAct)	46
ScanView Installation	22	Latching Relay (LRelAct)	46
Menu Navigation Tip	23	Acknowledging Relays	47
Setting Numeric Values	23	Pump Alternation Control Applications (RelAct)	47
Main Menu	23	Setting Up the Interlock Relay (Force On) Feature	48
Serial Communications (SERIAL)	24	<b>Scaling the 4-20 mA Analog Output (RelAct)</b>	<b>49</b>
Scanner Mode Selection	25	<b>Setting Up the Password (PASS)</b>	<b>49</b>
Operating Modes (MODE)	25	Protecting or Locking the Scanner	50
How to Enable Process Variables (PVs)	25		
Master Mode (Master)	26		
Snooper Mode (Snooper)	27		
How to Select 5 or 6-Digit Registers	28		

Making Changes to a Password Protected Scanner-----	50	Digital Input Menu (d I I)-----	66
Disabling Password Protection -----	50	Digital Output Menu (d O I) -----	66
<b>Advanced Features Menu-----</b>	<b>51</b>	Reset Function (reset)-----	66
Advanced Menu Navigation Tips: -----	51	4-20 mA Output Calibration -----	67
Advanced Features Menu & Display Messages -----	52	<b>Troubleshooting -----</b>	<b>68</b>
Scan Function (S Rn) -----	54	<b>Diagnostics Menu (d iRG) -----</b>	<b>69</b>
Control Menu (C nErL) -----	54	Determining Software Version -----	69
Noise Filter (F iLEr) -----	55	Reset Scanner to Factory Defaults -----	69
Noise Filter Bypass (bYPRSS) -----	55	Testing the Display LEDs-----	69
Rounding Feature (rOuNd)-----	55	<b>Scanner Operation-----</b>	<b>70</b>
Select Menu (SELEct) -----	55	<b>Front Panel Buttons Operation-----</b>	<b>70</b>
Analog Output Source Programming (RouLEPr) -----	64	<b>Function Keys Operation-----</b>	<b>70</b>
User Menu (uSEr)-----	65	<b>F4 Operation-----</b>	<b>70</b>
		<b>Maximum/Minimum Readings -----</b>	<b>70</b>
		<b>Factory Defaults &amp; User Settings-----</b>	<b>71</b>

## Table of Figures

Figure 1. 1/8 DIN Panel Cutout Dimensions & Panel Mounting Details -----	11	Figure 9. Relay Connections -----	16
Figure 2. Scanner Dimensions - Side View -----	12	Figure 10. AC and DC Loads Protection -----	16
Figure 3. Scanner Dimensions - Top View -----	12	Figure 11. Low Voltage DC Loads Protection --	16
Figure 4. Connector Labeling for Fully Loaded DPM-100-----	13	Figure 12. 4-20 mA Output Connections -----	17
Figure 5. Power Connections -----	13	Figure 13. Interlock Connections -----	17
Figure 6. Serial Communications Connections	14	Figure 14. Acknowledge Relays with F4 Function Key-----	47
Figure 7. Three-Wire RS485 Connection -----	15	Figure 15. Acknowledge Relays with Digital Input -----	47
Figure 8. F4 Digital Input Connections-----	15		

## Introduction

The BinMaster DPM-100 Modbus® Scanner is a multi-purpose, easy-to-use digital scanner that can be programmed as a Modbus RTU Master, Slave, or Snooper. It is capable of scanning up to 16 variables generated by any Modbus device, which makes it ideal for tank level monitoring and control. Its superluminous LED digits make it easily readable in smoke, dust, fog, and even direct sunlight.

As a master, the DPM-100 reads up to 16 slave devices, scales the data from each, displays the result, and operates the internal relays and 4-20 mA output. The DPM-100 in Master mode is capable of polling up to 16 process variables (PVs); it displays all the enabled PVs in sequence, at a user programmable scan rate; it also allows other DPM-100s in Snooper mode to read any of the variables being polled by the master. As a snooper, the DPM-100 listens to the Modbus traffic and picks up a specific register or registers being polled by a master device from a specific slave device and processes the data being read. As a slave, it is controlled by a master device. The data sent to it by the master is scaled, displayed, and used to operate the relays and 4-20 mA output.

The DPM-100 is housed in a 1/8 DIN panel scanner enclosure that features a NEMA 4X front panel. Data is displayed on an adjustable intensity, dual-line, six-digit display. The upper display is a 0.6 inch, seven-segment LED display, while the lower display digit height is 0.46 inches. The Super Snooper can be powered from 85-265 VAC or 12-36 VDC. It is available with up to 4 internal relays and is available with 4 additional relays and up to 8 digital inputs/outputs, as well as a dual 4-20 mA output expansion module, as options.

Various math functions may be applied to the Modbus including addition, difference, absolute difference, average, weighted average, multiplication, division, minimum, maximum, draw, ratio, and concentration. This is in addition to the signal input conditioning functions (linear, square root, programmable exponent, or round horizontal tank calculations). The displays, relays, and the analog outputs may be assigned to PVs or to math channels C1, C2, C3, or C4. The digital inputs/outputs can be custom-programmed for specific operations. A digital input (F4) is standard.

Free ScanView software allows a Super Snooper Modbus Scanner to be accessed with a computer. Configure multiple scanners, conveniently monitor critical information, and Datalog right from a PC with ease, further increasing plant efficiency.

## Ordering Information

### DPM-100 Model Numbers

<b>85-265 VAC Power Model Numbers</b>	<b>Reorder Number</b>	<b>Options Installed</b>
PD6088-6H0-BM	348-0029	No options
PD6088-6H2-BM	348-0026	2 relays
PD6088-6H3-BM	348-0024	4-20 mA output
PD6088-6H4-BM	348-0035	4 relays
PD6088-6H5-BM	348-0027	2 relays & 4-20 mA output
PD6088-6H7-BM	348-0025	4 relays & 4-20 mA output
<b>12-24 VDC Power Model Numbers</b>	<b>Reorder Number</b>	<b>Options Installed</b>
PD6088-7H0-BM	348-0028	No options
PD6088-7H2-BM	348-0031	2 relays
PD6088-7H3-BM	348-0032	4-20 mA output
PD6088-7H4-BM	348-0036	4 relays
PD6088-7H5-BM	348-0033	2 relays & 4-20 mA output
PD6088-7H7-BM	348-0034	4 relays & 4-20 mA output

### Accessories

<b>Model</b>	<b>Description</b>
PDA1002	DIN rail mounting kit for two expansion modules
PDA1004	4 SPST (Form A) relays
PDA1011	Dual 4-20 mA expansion module
PDA1044	4 digital inputs & 4 digital outputs (2 may be connected)
PDA1485	RS-485 serial adapter - (Included with DPM-100)
PDA7485-I	RS-232 to RS-422/485 isolated converter
PDA7485-N	RS-232 to RS-422/485 non-isolated converter
PDA8485-I	USB to RS-422/485 isolated converter
PDA8485-N	USB to RS-422/485 non-isolated converter
PDX6901	Suppressor (snubber): 0.01 $\mu$ F/470 $\Omega$ , 250 VAC

Manufactured by Precision Digital Corporation, 233 South St, Hopkinton MA 01748 USA

# Specifications

Except where noted all specifications apply to operation at +25°C.

## Operating Modes

<b>Master</b>	Processes data read from Modbus RTU slave devices. It polls up to 16 process variables from 1 to 16 slave devices. The Master is capable of scanning the selected PVs, scaling the data, triggering relays, performing math operations, and driving the analog outputs.
<b>Snooper</b>	Listens to the Modbus traffic and picks up a specific register or registers being polled by a master device from a specific slave device and processes the data being read. The Snooper mode handles the data the same way as the Master.
<b>Slave</b>	Processes data sent to it from a Modbus RTU master device. <i>Note: The relays and the 4-20 mA outputs are functional in all modes.</i>

## Master & Snooper Settings

<b>PV Number</b>	PV1–PV16 Enable or disable the process variables to be polled by the Master.
<b>Slave Id</b>	Assign the slave ID or address (1-247) containing the process variables to be displayed by the selected PV.
<b>Function Code</b>	Select which Modbus function code (03, 04, or 65) to use in reading the slave device.
<b>Register Number</b>	5 digit: 30001-39999, 40001-49999, or 1-65,536 6 digit: 300001-365536 or 400001-465536 (Function Code 65 N/A here) Specifies which register(s) to read in the slave device. Range is dependent on Function Code selection (65, 04, or 03) and digits selection (5 or 6).
<b>Data Type</b>	Select the data format that the slave device uses. Select between Short integer (2 byte), Long integer (4 byte), or floating point (4 byte), Signed or Unsigned (integer only) and byte order: 1234, 4321, 2143, or 3412 (big-endian vs. little-endian, or swapped).
<b>Poll Time</b>	1.0 to 99.9 sec. Time between read-commands (Master mode).
<b>Slave Response Timeout</b>	0.0 to 99.9 seconds: Time allowed for the slave to respond before the scanner generates a communication break condition. The master polls the slave 3 times before starting the response timeout timer. Slave/Snooper mode: Time the scanner will wait for new data before going into break condition. Slave mode: Programming 0 disables the timeout; the last value received will be displayed indefinitely.

<b>Communication Break</b>	Displays " <b>br-ERR</b> " after the Master has polled the slave device 3 times and the response timeout has elapsed. The Snooper and Slave modes go into break condition after no new data is received within the response timeout window. Relays can be programmed to go on, off, or ignore the break condition. The analog outputs can be setup to generate a fixed mA current when a break condition is detected.
----------------------------	---

## PV Settings

<b>Tag &amp; Units</b>	6-character, independent tag and units for each PV and math channel
<b>PV Format</b>	Decimal format (default) or FT & IN, 1/8th or 1/16th; decimal format may be selected for line 2 indication.
<b>Display Decimal Point</b>	Up to five decimal places or none: <b>d.ddddd</b> , <b>dd.ddddd</b> , <b>ddd.dddd</b> , <b>dddd.dd</b> , <b>dddd.d</b> , or <b>dddddd</b>
<b>Float Decimal Point</b>	Select the number of decimals to use for the floating point data expected from the slave or master device (this is independent from the display decimal point selection).
<b>PV &amp; Math Scaling</b>	All PVs and math channels may be scaled to represent the input data in any engineering unit. Example: Level transmitter = 999.999 inches; to display in Ft-In-1/16 <sup>th</sup> scale input 2 to display 83 Ft – 4 In – 0/16 <sup>th</sup> .

## Display Settings

<b>Scan Mode</b>	Automatic: 1.0 to 99.9 sec Manual: Front panel or digital inputs Go on alarm: Continues scanning after an alarm is detected Stop on alarm: Goes to the alarmed PV and stops scanning; press Scan to resume scanning.
<b>Display Scan Rate</b>	Master/Snooper: 1 PV/second to one PV every 99.9 seconds Slave: Dependent on master device (e.g. PLC) <i>Note: The display scan rate is independent of the poll time.</i>
<b>Display Assignment</b>	Display line 1 may be assigned to PV (process values), Ch-C (math channel), PV & units, tag & PV, tag-PV-units, C & units, tag-C-unit, Set point 1-8, max/min PV, max/min C. Line 2 may be assigned to all of the above, tag, tag & units, or off. The tag and units are displayed alternately for 2 sec max, when selected. Different tags & PVs may be selected to display on line 1 and 2 at the same time.

## Math Functions

Name	Math Operation (Examples) (P = Adder, F = Factor)	Setting
Addition	$(PV1+PV2+P)*F$	Sum
Difference	$(PV1-PV2+P)*F$	d.F
Absolute difference	$((Abs(PV1- PV2)+P)*F$	d.FAbs
Average	$((PV1+PV2)/2)+P)*F$	AUG
Multiplication	$((PV1*PV2)+P)*F$	mulE
Division	$((PV1/PV2)+P)*F$	d.U.dE
Max PV	Max value of all selected PVs	H.-PU
Min PV	Min value of all selected PVs	Lo-PU
Draw	$((PV1/PV2)-1)*F$	drAU
Weighted average	$((PV2-PV1)*F)+PV1$	u.AUG
Ratio	$(PV1/PV2)*F$	rAtE
Concentration	$(PV1/(PV1+PV2))*F$	ConcEn
Math 2	Math on other math channels	math2

**Programmable Constants**  
 Constant P (Adder): -99.999 to 999.999, default: 0.000  
 Constant F (Factor): 0.001 to 999.999, default: 1.000

## Serial Communications

<b>Scanner Id</b>	1 – 247 (Scanner Modbus address)
<b>Baud Rate</b>	300 – 19,200 bps
<b>Transmit Time Delay</b>	Programmable 0 to 4999 ms This is the time the scanner will wait for a slave to respond before sending another request on the bus. This value should be greater than 100 ms to avoid collisions on the bus.
<b>Data</b>	8 bits (1 start bit, 1 or 2 stop bits)
<b>Parity</b>	Even, Odd, or None with 1 or 2 stop bits
<b>Byte-To-Byte Timeout</b>	0.01 – 2.54 second
<b>Turn Around Delay</b>	Less than 2 ms (fixed)

*Note: Refer to the Scanner Modbus Register Tables located at [www.binmaster.com](http://www.binmaster.com).*

## General

<b>Input/output</b>	Modbus RTU over RS-485
<b>Display</b>	Line 1: 0.60" (15 mm) high, red LEDs Line 2: 0.46" (12 mm) high, red LEDs 6 digits each (-99999 to 999999), with lead zero blanking
<b>Display Intensity</b>	Eight user selectable intensity levels
<b>Overrange</b>	Values greater than <b>999999</b> cause the display to flash <b>999999</b>
<b>Underrange</b>	Values less than <b>-99999</b> cause the display to flash <b>-99999</b>
<b>Programming Methods</b>	Four front panel buttons, digital inputs, PC and ScanView software, Modbus registers, or cloning using Copy function.

<b>Max/Min Display</b>	Max/min readings are stored until reset by the user or when power to the scanner is turned off. User can reset by front panel pushbuttons, digital input, or via Modbus registers.
<b>Password</b>	Three programmable passwords restrict modification of programmed settings. Pass 1: Allows use of function keys and digital inputs Pass 2: Allows use of function keys, digital inputs and editing set/reset points Pass 3: Restricts all programming, function keys, and digital inputs.
<b>F4 Digital Input Contacts</b>	50k ohm pull-up to 3.3 VDC. Connect normally open contacts across F4 to COM.
<b>F4 Digital Input Logic Levels</b>	Logic High: 3 to 5 VDC Logic Low: 0 to 1.25 VDC
<b>Non-Volatile Memory</b>	All programmed settings are stored in non-volatile memory for a minimum of ten years, with or without power.
<b>Power Options</b>	85-265 VAC 50/60 Hz, 90-265 VDC, 20 W max or 12-24 VDC $\pm$ 10%, 15 W max Powered over USB for configuration only.
<b>Fuse</b>	Required external fuse: UL Recognized, 5 A max, slow blow; up to 6 scanners may share one 5 A fuse
<b>Isolation</b>	4 kV input/output-to-power line. 500 V input-to-output or output-to-P+ supply
<b>Overvoltage Category</b>	Installation Overvoltage Category II: Local level with smaller transient overvoltages than Installation Overvoltage Category III.
<b>Environmental</b>	Operating temperature range: -40 to 65°C Storage temperature range: -40 to 85°C Relative humidity: 0 to 90% non-condensing
<b>Connections</b>	Removable screw terminal blocks accept 12 to 22 AWG wire, RJ45 for external relays, digital I/O, and serial communication adapters.
<b>Enclosure</b>	1/8 DIN, high impact plastic, UL 94V-0, color: black
<b>Mounting</b>	1/8 DIN panel cutout required: 3.622" x 1.772" (92 mm x 45 mm) Two panel mounting bracket assemblies are provided.
<b>Tightening Torque</b>	Screw terminal connectors: 5 lb-in (0.56 Nm)
<b>Overall Dimensions</b>	2.45" x 4.68" x 4.19" (62 mm x 119 mm x 106 mm) (H x W x D)
<b>Weight</b>	9.5 oz (269 g)
<b>Warranty</b>	3 years parts and labor



## Relays

<b>Rating</b>	2 or 4 SPDT (Form C) internal and/or 4 SPST (Form A) external; rated 3 A @ 30 VDC and 125/250 VAC resistive load; 1/14 HP (~ 50 W) @ 125/250 VAC for inductive loads
<b>Noise Suppression</b>	Noise suppression is recommended for each relay contact switching inductive loads.
<b>Electrical Noise Suppression</b>	A suppressor (snubber) should be connected to each relay contact switching inductive loads to prevent disruption to the microprocessor's operation. Recommended suppressor value: 0.01 µF/470 Ω, 250 VAC (PDX6901).
<b>Deadband</b>	0-100% of span, user programmable
<b>High Or Low Alarm</b>	User may program any alarm for high or low trip point. Unused alarm LEDs and relays may be disabled (turn off).
<b>Relay Operation</b>	Automatic (non-latching) Latching (requires manual acknowledge) Sampling (based on time) Pump alternation control (2 to 8 relays) Off (disable unused relays and enable Interlock feature) Manual on/off control mode
<b>Relay Reset</b>	User selectable via front panel buttons, digital inputs, or PC <ol style="list-style-type: none"> <li>Automatic reset only (non-latching), when the input passes the reset point.</li> <li>Automatic + manual reset at any time (non-latching)</li> <li>Manual reset only, at any time (latching)</li> <li>Manual reset only after alarm condition has cleared (L)</li> </ol> <p><i>Note: Front panel button or digital input may be assigned to acknowledge relays programmed for manual reset.</i></p>
<b>Time Delay</b>	0 to 999.9 seconds, on & off relay time delays. Programmable and independent for each relay
<b>Fail-Safe Operation</b>	Programmable and independent for each relay. <i>Note: Relay coil is energized in non-alarm condition. In case of power failure, relay will go to alarm state.</i>
<b>Auto Initialization</b>	When power is applied to the scanner, relays will reflect the state of the input to the scanner.

## Isolated 4-20 mA Transmitter Output

<b>Output Source</b>	PV1-16, math channels C1-4, set points 1-8, or manual control mode									
<b>Scaling Range</b>	1.000 to 23.000 mA for any display range									
<b>Calibration</b>	Factory calibrated: 4.000 to 20.000 = 4-20 mA output									
<b>Analog Out Programming</b>	23.000 mA maximum for all parameters: Overrange, underrange, max, min, and break									
<b>Communications Break</b>	Programmable mA output when a slave device does not reply within the response timeout.									
<b>Accuracy</b>	± 0.1% of span ± 0.004 mA									
<b>Temperature Drift</b>	0.4 µA/°C max from 0 to 65°C ambient, 0.8 µA/°C max from -40 to 0°C ambient. <i>Note: Analog output drift is separate from input drift.</i>									
<b>Isolated Transmitter Power Supply</b>	Terminals I+ & R: 24 VDC ± 10%. May be used to power the 4-20 mA output or other devices. Refer to Figure 4 on page 13 and Figure 12 on page 17. All models rated @ 40 mA max.									
<b>External Loop Power Supply</b>	35 VDC maximum									
<b>Output Loop Resistance</b>	<table border="1"> <thead> <tr> <th>Power supply</th> <th>Minimum</th> <th>Maximum</th> </tr> </thead> <tbody> <tr> <td>24 VDC</td> <td>10 Ω</td> <td>700 Ω</td> </tr> <tr> <td>35 VDC (external)</td> <td>100 Ω</td> <td>1200 Ω</td> </tr> </tbody> </table>	Power supply	Minimum	Maximum	24 VDC	10 Ω	700 Ω	35 VDC (external)	100 Ω	1200 Ω
Power supply	Minimum	Maximum								
24 VDC	10 Ω	700 Ω								
35 VDC (external)	100 Ω	1200 Ω								

## MeterView Pro

<b>System Requirements</b>	Microsoft® Windows® XP/Vista/7/8/10
<b>Communications</b>	USB 2.0 (Standard USB A to Micro USB B)
<b>Configuration</b>	Configure meters one at a time

## Compliance Information

### Safety

<b>UL &amp; c-UL LISTED</b>	USA & Canada UL 508 Industrial Control Equipment
<b>UL FILE NUMBER</b>	E160849
<b>FRONT PANEL</b>	UL Type 4X, NEMA 4X, IP65; panel gasket provided
<b>LOW VOLTAGE DIRECTIVE</b>	EN 61010-1:2010 Safety requirements for measurement, control, and laboratory use

### Electromagnetic Compatibility



<b>EMISSIONS</b>	EN 55022:2010 Class A ITE emissions requirements
Radiated Emissions	Class A
AC Mains Conducted Emissions	Class A
<b>IMMUNITY</b>	EN 61326-1:2013 Measurement, control, and laboratory equipment EN 61000-6-2:2005 EMC heavy industrial generic immunity standard
RFI - Amplitude Modulated	80 -1000 MHz 10 V/m 80% AM (1 kHz) 1.4 - 2.0 GHz 3 V/m 80% AM (1 kHz) 2.0 - 2.7 GHz 1 V/m 80% AM (1 kHz)
Electrical Fast Transients	±2kV AC mains, ±1kV other
Electrostatic Discharge	±4kV contact, ±8kV air
RFI - Conducted	10V, 0.15-80 MHz, 1kHz 80% AM
AC Surge	±2kV Common, ±1kV Differential
Surge	1KV (CM)
Power-Frequency Magnetic Field	30 A/m 70%V for 0.5 period
Voltage Dips	40%V for 5 & 50 periods 70%V for 25 periods
Voltage Interruptions	<5%V for 250 periods

**Note:**

*Testing was conducted on DPM-100 meters installed through the covers of grounded metal enclosures with cable shields grounded at the point of entry representing installations designed to optimize EMC performance.*

**Declaration of Conformity available at [www.binmaster.com](http://www.binmaster.com)**

## Safety Information

 <b>CAUTION:</b>	<p><i>Read complete instructions prior to installation and operation of the scanner.</i></p>	 <b>WARNING!</b>	<p><b><i>Risk of electric shock or personal injury. Hazardous voltages exist within enclosure. Installation and service should be performed only by trained service personnel.</i></b></p>
--	--	--	--

## Installation

There is no need to remove the scanner from its case to complete the installation, wiring, and setup of the scanner.

## Unpacking

Remove the scanner from box. Inspect the packaging and contents for damage. Report damages, if any, to the carrier. If any part is missing or the scanner malfunctions, please contact your supplier or the factory for assistance.

## Panel Mounting

- Prepare a standard 1/8 DIN panel cutout – 3.622" x 1.772" (92 mm x 45 mm). Refer to Figure 1 for more details.
- Clearance: allow at least 6" (152 mm) behind the panel for wiring.
- Panel thickness: 0.04" - 0.25" (1.0 mm - 6.4 mm).  
Recommended minimum panel thickness to maintain Type 4X rating: 0.06" (1.5 mm) steel panel, 0.16" (4.1 mm) plastic panel.
- Remove the two mounting brackets provided with the scanner (back-off the two screws so that there is ¼" (6.4 mm) or less through the bracket. Slide the bracket toward the front of the case and remove).
- Insert scanner into the panel cutout.
- Install mounting brackets and tighten the screws against the panel. To achieve a proper seal, tighten the mounting bracket screws evenly until scanner is snug to the panel along its short side. **DO NOT OVER TIGHTEN**, as the rear of the panel may become damaged.

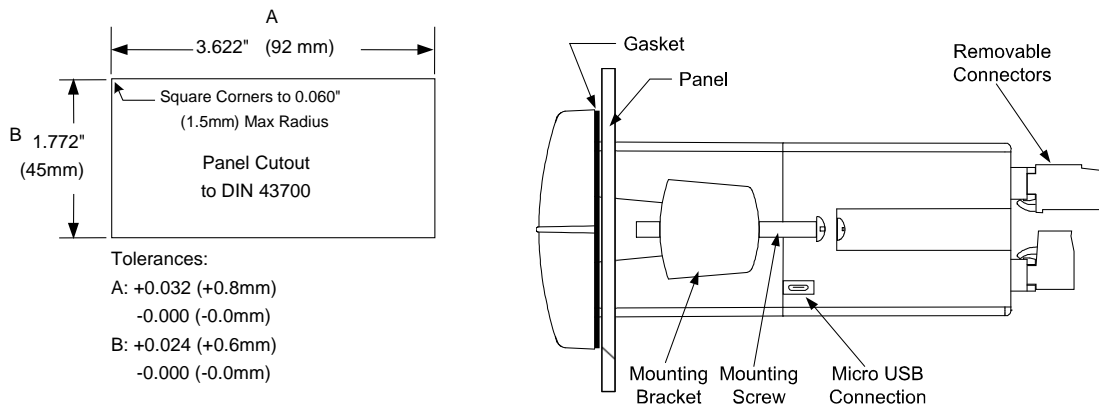

**Mounting Dimensions**

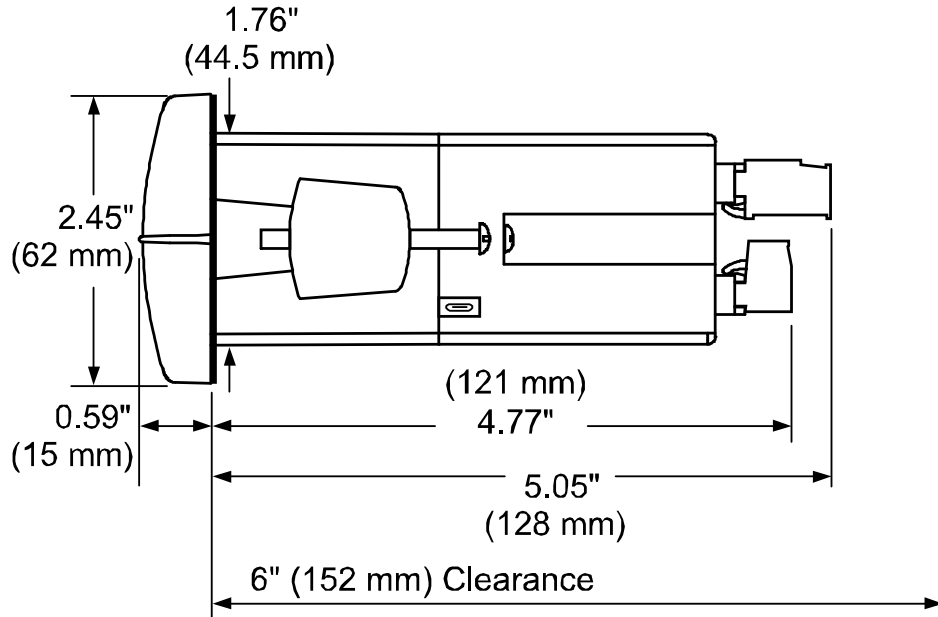

**Figure 2. Scanner Dimensions - Side View**

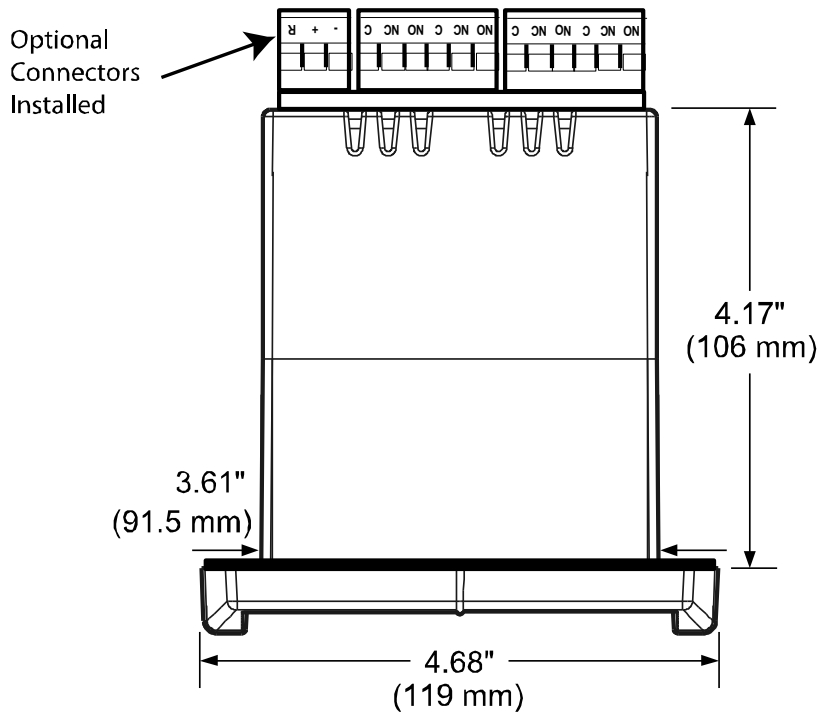

**Figure 3. Scanner Dimensions - Top View**

## Connections

All connections are made to removable screw terminal connectors located at the rear of the scanner.



**Caution!** Use copper wire with 60°C or 60/75°C insulation for all line voltage connections. Observe all safety regulations. Electrical wiring should be performed in accordance with all applicable national, state, and local codes to prevent damage to the scanner and ensure personnel safety.

## Connectors Labeling

The connectors' label, affixed to the scanner, shows the location of all connectors available with requested configuration.



**Warning!** Do not connect any equipment other than BinMaster's expansion modules, cables, or scanners to the RJ45 M-LINK connector. Otherwise damage will occur to the equipment and the scanner.

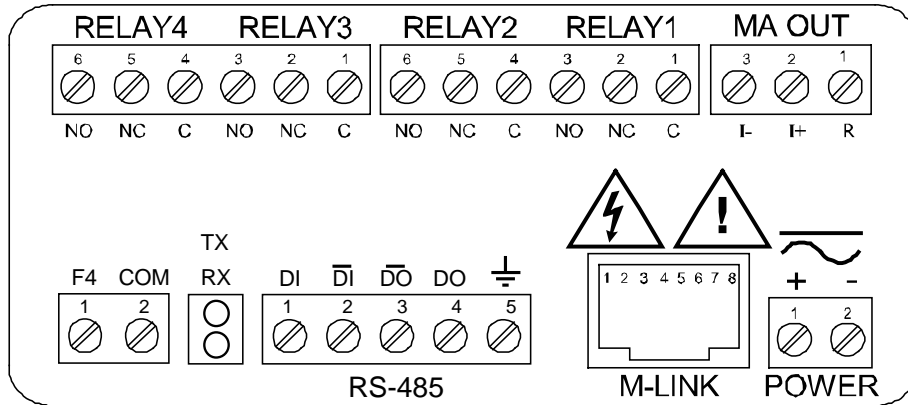

Figure 4. Connector Labeling for Fully Loaded DPM-100

## Power Connections

Power connections are made to a two-terminal connector labeled POWER on the back of the scanner. The scanner will operate regardless of DC polarity connection. The + and - symbols are only a suggested wiring convention.

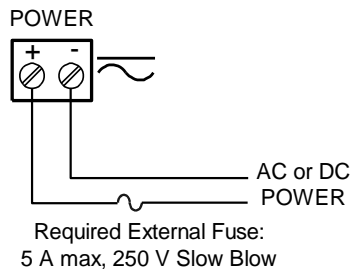

Figure 5. Power Connections

### Serial Communications Connection

Serial communications connection is made to an RJ45 connector labeled M-LINK on the back of the scanner. The Modbus Scanner uses the PDA1485 RS-485 adapter to interface with other Modbus devices and the PDA8485 RS-485 to USB converter or PDA7485 RS-232 to RS-485 converter to connect to a PC. The same port is used for interfacing with all expansion modules (e.g. external relays, digital I/O).

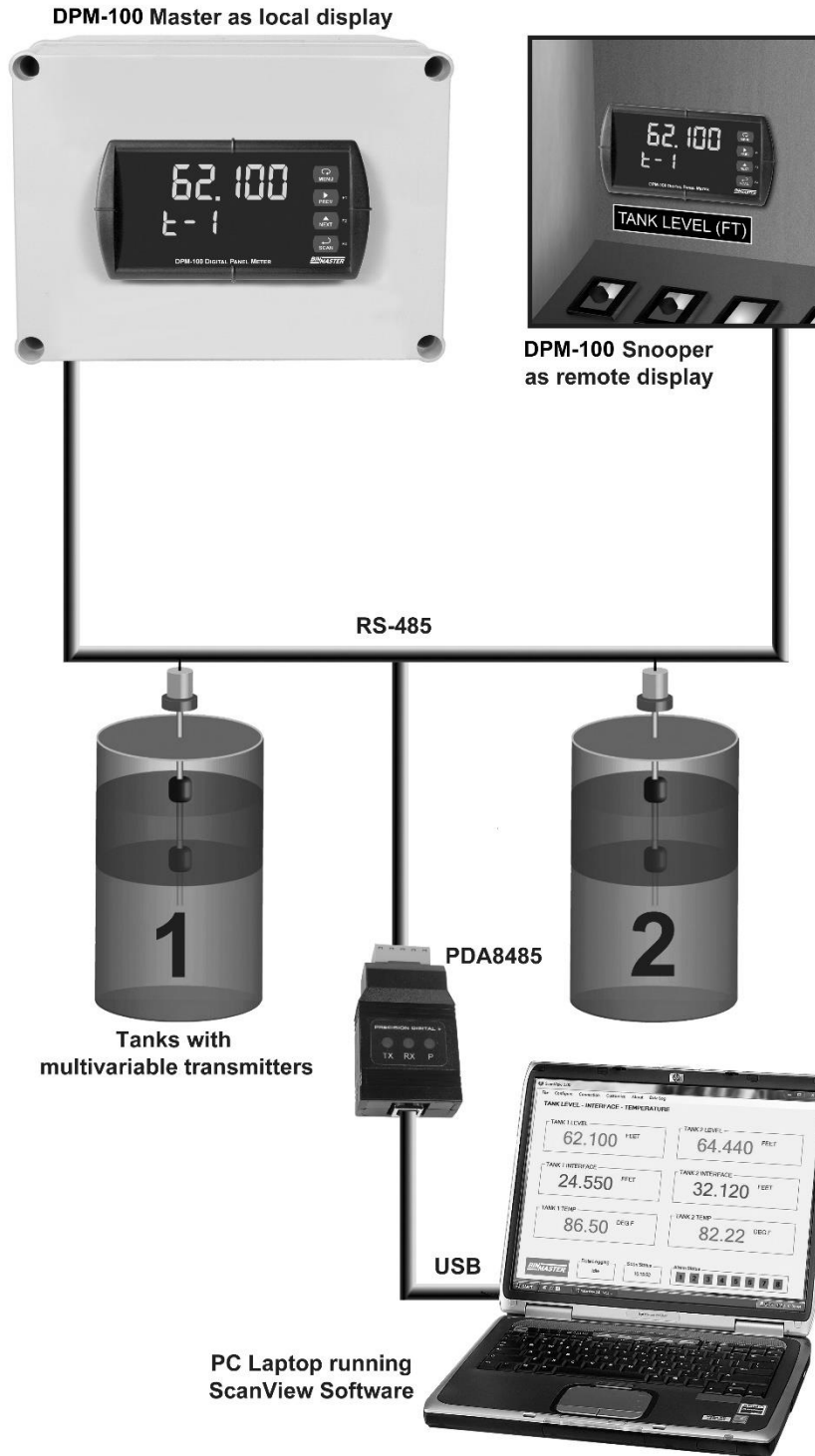

Figure 6. Serial Communications Connections

### Serial Communications Connections Table

The table below shows the terminal connections for 3-wire RS-485 devices.

DPM-100 Master	DPM-100 Snooper	PC Connection	Modbus Slave Meter	Modbus Level Gauge
PDA1485 RS-485 Adapter	PDA1485 RS-485 Adapter	PDA8485 RS-485 to USB	RS-485	RS-485
			G	GND
$\overline{DI} - \overline{DO}$	$\overline{DI} - \overline{DO}$	$\overline{DI} - \overline{DO}$	D-	A (-)
DI - DO	DI - DO	DI - DO	D+	B (+)

### Three Wire Connections

In order to wire the 5 pins for use as a 3-wire half-duplex RS-485 connection, it is necessary to create a jumper connection between DI – DO and  $\overline{DI} - \overline{DO}$  - as shown below.

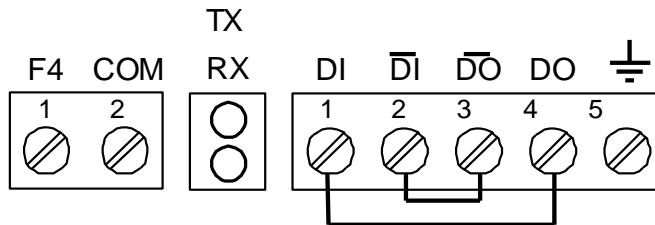

Figure 7. Three-Wire RS485 Connection

### F4 Digital Input Connections

A digital input, F4, is standard on the scanner. This digital input connected with a normally open closure across F4 and COM, or with an active low signal applied to F4.

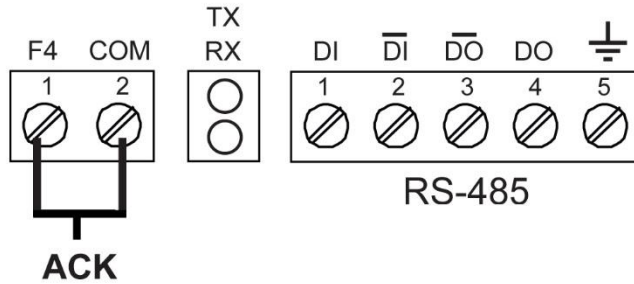

Figure 8. F4 Digital Input Connections

### Relay Connections

Relay connections are made to two six-terminal connectors labeled RELAY1 – RELAY4 on the back of the scanner. Each relay's C terminal is common only to the normally open (NO) and normally closed (NC) contacts of the corresponding relay. The relays' C terminals should not be confused with the COM (common) terminal of the INPUT SIGNAL connector.

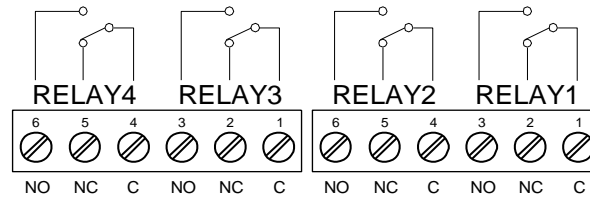

Figure 9. Relay Connections

### Switching Inductive Loads

The use of suppressors (snubbers) is strongly recommended when switching inductive loads to prevent disrupting the microprocessor's operation. The suppressors also prolong the life of the relay contacts. Suppression can be obtained with resistor-capacitor (RC) networks assembled by the user or purchased as complete assemblies. Refer to the following circuits for RC network assembly and installation:

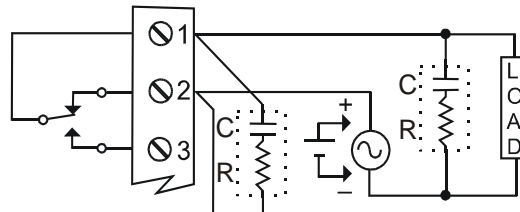

Figure 10. AC and DC Loads Protection

#### Choose R and C as follows:

- R: 0.5 to 1  $\Omega$  for each volt across the contacts
- C: 0.5 to 1  $\mu\text{F}$  for each amp through closed contacts

#### Notes:

1. Use capacitors rated for 250 VAC.
2. RC networks may affect load release time of solenoid loads. Check to confirm proper operation.
3. Install the RC network at the scanner's relay screw terminals. An RC network may also be installed across the load. Experiment for best results.

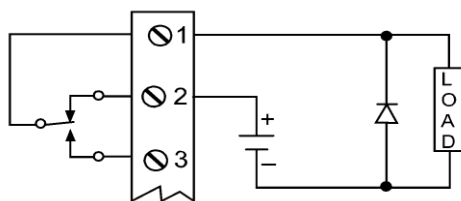

Use a diode with a reverse breakdown voltage two to three times the circuit voltage and forward current at least as large as the load current.

Figure 11. Low Voltage DC Loads Protection  
DCLoadProt

### RC Networks Available from BinMaster

RC networks are available from BinMaster and should be applied to each relay contact switching an inductive load. Part number: PDX6901.

Note: Relays are de-rated to 1/14 HP (50 watts) with an inductive load.



### 4-20 mA Output Connections

Connections for the 4-20 mA transmitter output are made to the connector terminals labeled MA OUT. The 4-20 mA output may be powered internally or from an external power supply.

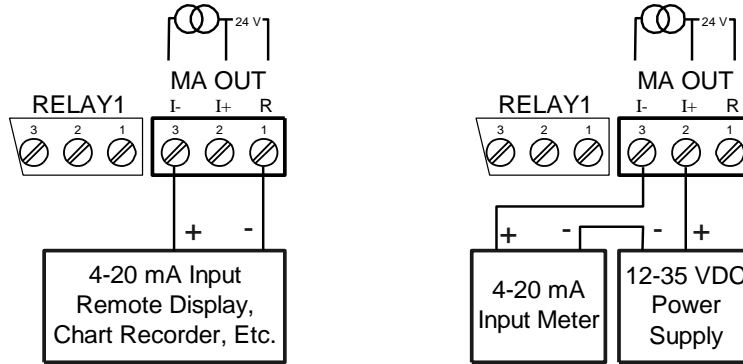

Figure 12. 4-20 mA Output Connections

### Analog Output Transmitter Power Supply

The internal 24 VDC power supply powering the analog output may be used to power other devices, if the analog output is not used. The I+ terminal is the +24 V and the R terminal is the return.

### External Relay, Analog Output, & Digital I/O Connections

The relay, analog out, and digital I/O expansion modules PDA1004, PDA1011, and PDA1044 are connected to the scanner using a CAT5 cable provided with each module. The two RJ45 connectors on the I/O expansion modules are identical and interchangeable; they are used to connect additional modules to the system. See LIM1044, Expansion Module Instruction Manual, for details.

*Note: The jumper located between the RJ45 connectors of the PDA1044 must be removed on the second digital I/O module in order for the system to recognize it as module #2.*



**Warning!** *Do not connect or disconnect the expansion modules with the power on! More detailed instructions are provided with each optional expansion module.*

### Interlock Relay Feature

As the name implies, the interlock relay feature reassigns one, or more, alarm/control relays for use as interlock relay(s). Interlock contact(s) are wired to digital input(s) and trigger the interlock relay. This feature is enabled by configuring the relay and relative digital input(s). In one example, dry interlock contacts are connected in series to one digital input which will be used to force on (energize) the assigned interlock power relay when all interlock contacts are closed (safe). The interlock relay front panel LED flashes when locked out. The interlock relay would be wired in-series with the load (N/O contact). See below.

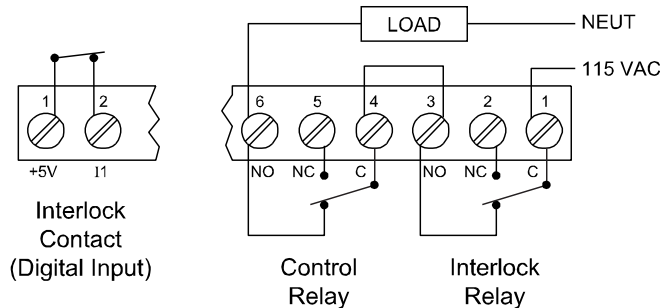

Figure 13. Interlock Connections

## Setup and Programming

### Overview



There are no jumpers involved in the scanner setup procedure.

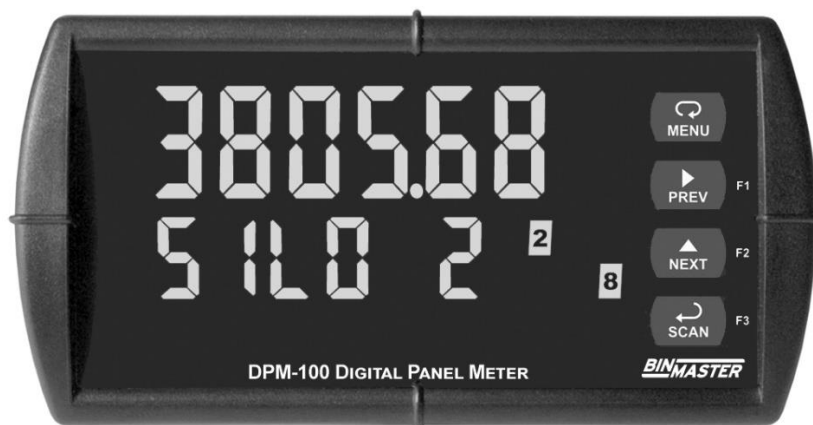

Setup and programming is done using ScanView software or through the front panel buttons.

After power and signal connections have been completed and verified, apply power to the scanner.

### Front Panel Buttons and Status LED Indicators

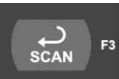

Button Symbol	Description
	Menu
	PREV/Right arrow/F1
	NEXT/Up arrow/F2
	SCAN/Enter/F3
<b>PREV</b>	Go to previous PV
<b>NEXT</b>	Go to next PV

LED	Status
1-8	Alarm 1-8 indicator
1-8 <b>M</b>	Flashing: Relay in manual control mode
1-4	Flashing: Relay interlock switch open
<b>F</b>	Communications Fault Condition
 <b>PAUSE</b>	Press SCAN to pause scanning
 <b>PLAY</b>	Press SCAN to resume scanning
 <b>STOP</b>	Stop scan on alarm
<p><b>Note 1:</b> F4 is a digital input. Alarms 5-8 are enabled when relay expansion module installed.</p> <p><b>Note 2:</b> LEDs for relays in manual mode flash with the "M" LED every 10 seconds.</p>	

- Press the Menu button to enter or exit the Programming Mode at any time.
- Press the Right arrow button to move to the next digit during digit or decimal point programming.
- Press the Up arrow button to scroll through the menus, decimal point, or to increment a digit.
- Press the Enter button to access a menu or to accept a setting.
- Press and hold the Menu button for three seconds to access the advanced features of the scanner.
- Press the SCAN/Enter button once to pause scanning (Pause LED flashes), then press the SCAN/Enter button again to resume scanning (Play LED turns on).
- Press NEXT to go to the next PV; auto scan resumes after 10 seconds of inactivity.
- Press PREV to go to the previous PV; auto scan resumes after 10 seconds of inactivity.

## Display Functions & Messages

The following table shows the main menu functions and messages in the order they appear in the menu.

Display	Parameter	Description	Display	Parameter	Description
ጠ ሰድ	Mode	Enter Mode menu	ፔ-ፕፎ5ፑ	Response Time	Enter the time allowed for a slave device to respond to a command.
ጠ ሰ5ፔፎፕ	Master	Enter Master Mode	5ጠፎፑፎፕ	Snooper	Enter Snooper Mode
ፑፊጠጠጠ	PV Number	Select PV	ፑፊጠጠጠ	PV Number	Select PV
ፑፊ 1	PV	Select PV 1-16	ፑፊ 1	PV	Select PV 1-16
ፎጠፑፊፎፕ	Enable	Enable PV	ፎጠፑፊፎፕ	Enable	Enable PV
ፊ ፊፑፑፊፊ	Disable	Disable PV	ፊ ፊፑፑፊፊ	Disable	Disable PV
5ፊፑፊፊ ፊፊ	Slave ID	Enter the unique Slave ID for each PV	5ፊፑፊፊ ፊፊ	Slave ID	Enter the unique Slave ID of the device to be polled by Master
ፑፊፊፊፊፊ	Function Code	Enter the Function Code for each PV	ፑፊፊፊፊፊ	Function Code	Enter the Function Code for each PV
ፕፎፊፊጠጠጠ	Register Number	Enter the Register Number for each PV	ፕፆጠ 03	Function Code 03	Use Function Code 03 to read slave device
ፊፑፔፑ	Data Type	Enter the Data Type for each PV	ፕፆጠ 04	Function Code 04	Use Function Code 04 to read slave device
ፑፊፊፊፊ	Floating Point Data Type	Floating Point Data Type. Select <i>Floating Point</i> as the data type to be read from the slave device.	ፕፆጠ 65	Function Code 65	Use Function Code 65 to read slave device
5ጠፊፊፊፊ	Short Integer Data Type	Short Integer Data Type. Select <i>Short Integer</i> as the data type to be read from the slave device.	ፕፆፊፊፊጠጠጠ	Register Number	Enter the Register Number for each PV
ፊጠፊፊፊ	Long Integer Data Type	Long Integer Data Type. Select <i>Long Integer</i> as the data type to be read from the slave device.	5 ፊ ፊፊፊ	Register Number Digits	Select either 5 (x0001-x9999) or 6 (x00001-x65536) digits for the Register Number by pressing the Right Arrow in Register Number menu.
ፊ ጠፑፑፑፑ	Binary	Binary Data format. Select <i>Binary</i> format for Short or Long integers.	ፊፑፔፑ	Data Type	Enter the Data Type for each PV
ፊፊፊፊ	BCD	BCD Data format. Select <i>BCD</i> format for Short or Long integers.	ፑፊፊፊፊ	Floating Point Data Type	Floating Point Data Type. Select <i>Floating Point</i> as the data type to be read from the slave device.
5 ፊፊፊፊፊፊ	Signed	Signed Data. Select <i>Signed</i> Binary format for Short or Long integers.	5ጠፊፊፊፊ	Short Integer Data Type	Short Integer Data Type. Select <i>Short Integer</i> as the data type to be read from the slave device.
ፊጠ5 ፊፊፊፊ	Unsigned	Unsigned Data. Select <i>Unsigned</i> Binary format for Short or Long integers.	ፊጠፊፊፊ	Long Integer Data Type	Long Integer Data Type. Select <i>Long Integer</i> as the data type to be read from the slave device.
ፊ234	Byte Order	Select big-endian byte order.	ፊ ጠፑፑፑፑ	Binary	Binary Data. Select <i>Binary</i> format for Short or Long integers.
432 1	Byte Order	Select little-endian byte order.	ፊፊፊፊ	BCD	BCD Data. Select <i>BCD</i> format for Short or Long integers.
24 13	Byte Order	Select byte-swapped big-endian byte order. Not available for Short integer.	5 ፊፊፊፊፊፊ	Signed	Signed Data. Select <i>Signed</i> Binary format for Short or Long integers.
34 12	Byte Order	Select byte-swapped little-endian byte order. Not available for Short integer.	ፊጠ5 ፊፊፊፊ	Unsigned	Unsigned Data. Select <i>Unsigned</i> Binary format for Short or Long integers.
ፔ-ፑፆፊፊፊ	Polling Time	Enter Polling Time (the time between read commands). In other words, how often the display is updated in Master mode.			

Display	Parameter	Description
1234	Byte Order	Select big-endian byte order.
4321	Byte Order	Select little-endian byte order.
2413	Byte Order	Select byte-swapped big-endian byte order. Not available for Short.
3412	Byte Order	Select byte-swapped little-endian byte order. Not available for Short.
ErrESP	Response Time	Enter the time allowed for a slave device to respond to a command.
SLAVE	Slave	Enter Slave Mode
dRtR	Data Type	Enter the Data Type for each PV
FLoRt	Floating Point Data Type	Floating Point Data Type. Select <i>Floating Point</i> as the data type to be read from the slave device.
Short	Short Integer Data Type	Short Integer Data Type. Select <i>Short Integer</i> as the data type to be read from the slave device.
LoRt	Long Integer Data Type	Long Integer Data Type. Select <i>Long Integer</i> as the data type to be read from the slave device.
binRtY	Binary	Binary Data. Select <i>Binary</i> format for Short or Long integers.
bcd	BCD	BCD Data. Select <i>BCD</i> format for Short or Long integers.
Signed	Signed	Signed Data. Select <i>Signed</i> Binary format for Short or Long integers.
unSigned	Unsigned	Unsigned Data. Select <i>Unsigned</i> Binary format for Short or Long integers.
1234	Byte Order	Select big-endian byte order.
4321	Byte Order	Select little-endian byte order.
2413	Byte Order	Select byte-swapped big-endian byte order. Not available for Short integer.
3412	Byte Order	Select byte-swapped little-endian byte order. Not available for Short integer.
ErrESP	Response Time	Enter the time allowed for a slave device to respond to a command.
SEtUP	Setup	Enter Setup menu
PV	Process Variable	Enter PV Setup menu
PV 1	PV	Select PV 1-16

Display	Parameter	Description
TRG	Tag	Tag
unItS	Units	Units
Format	Format	Format (Decimal, Eighths, or Sixteenths of an Inch)
dEc	Decimal	Decimal Format
EtIn8	Eighths	Eighth Inch Format
EtIn16	Sixteenths	Sixteenth Inch Format
dEcPt	Decimal Point	Decimal Point menu
dSPdP	Display Decimal Point	Set the decimal point position for the display. This is independent from float decimal point.
FLoTdP	Floating Decimal Point	Floating Decimal Point. Select the decimal point for the expected floating point data.
SCALE	Scale PV	Scale PV
InP 1	Input 1	Program input 1 value
dS 1	Display 1	Program display 1 value
InP 2	Input 2	Program input 2 value (up to 32 points for PV1 & PV2)
dS 2	Display 2	Program display 2 value (up to 32 points for PV1 & PV2)
dSPLY	Display	Enter Display Setup menu
LnE 1	Display Line 1	Top Display
dPV	Display PV	Display PVs 1-16
dCh-C	Display C Channel	Display Math Channels C1-C4
PVunIt	Display PV & Units	Display PV & Units
EtPUn	Display Tag, PV Number	Display Tag & PV Number selected
EtPUnu	Display Tag, PV# & Units	Display Tag, PV Number selected, & Units
LnIt	Display C & Units	Display C1-C4 & Units
Et.C.u	Display Tag, C, & Units	Display Tag, C1-C4 & Units & Units
dSEt 1	Display Set Points 1-8	Display Set Points 1-8
Hi-PV	Display Max PV 1-16	Display Maximum value for each enabled PV1-16
Lo-PV	Display Min PV 1-16	Display Minimum value for each enabled PV1-16
Hi-C	Display Max Ch C1-C4	Display Maximum for math channels C1-C4
Lo-C	Display Min Ch C1-C4	Display Minimum for math channels C1-C4
LnE 2	Display Line 2	Bottom Display
dTRG	Display Tag	Display Tag
dTRGu	Display Tag & Units	Display Tag & Units

Display	Parameter	Description	Display	Parameter	Description
d OFF	Display off	Display Off	OFF	Off	Relay goes to non-alarm condition when break detected. Relay turns off when Communications Break detected.
d- IntY	Display Intensity	Display Intensity	Rout	Analog output	Enter the Analog Output scaling menu
rELRY	Relay Setup	Enter Relay Setup menu	Rout *	Aout channel	Analog Output source channel (*1-3)
RSS Gn	Assign Relay	Assign Relay menu	d IS 1	Display 1	Program the first Display value for the Analog Output.
rELRY 1	Relay 1-8	Assign Relay 1-8	Out 1	Output 1	Program the first Output value that corresponds to the Display 1 value for the Analog Output. (e.g. 4.000 mA).
PV 1	PV 1-16	Map Relay to PV 1-16	d IS 2	Display 2	Program the second Display value for the Analog Output.
rr -PV	Multiple PVs	Map Relay to Multiple PVs	Out 2	Output 2	Program the second Output value that corresponds to the Display 2 value for the Analog Output. (e.g. 4.000 mA). (e.g. 20.000 mA)
rLY 1	Relay 1-8	Relay 1-8	SER iRL	Serial	Enter Serial menu
Rct 1	Relay Action 1-8	Assign Relay Action for relays 1-8	SCAN Id	Scan ID	Enter Scan ID of the meter being polled (1-247)
Ruto	Automatic	Set relay for automatic reset	brud	Baud Rate	Select Baud Rate (Choices: 300/600/1200/2400/4800/9600/19,200) (Must match that of other devices)
R-nrn	Auto-manual	Set relay for auto or manual reset any time	Er dLY	Transmit Delay	Enter Transmit Delay (Master's delay must be greater than Snooper or slave devices)
LRECH	Latching	Set relay for latching operation	PRr LY	Parity	Select Parity (Even, Odd, None 1-Stop, or None 2-Stop) (Must match that of other devices)
LE-CLR	Latching-cleared	Set relay for latching operation with manual reset only after alarm condition has cleared	t-byt	Byte-to-byte Timeout	Enter the timeout value allowed between received bytes. (This is used to fix communication problems with slow devices).
RLtErn	Alternate	Set relay for pump alternation control	PASS	Password	Enter the Password menu
SRn PL	Sample	Set relay for sample time trigger control	PASS 1	Password 1	Set or enter Password 1
OFF	Off	Turn relay off	PASS 2	Password 2	Set or enter Password 2
FR LSF	Fail-safe	Enter Fail-safe menu	PASS 3	Password 3	Set or enter Password 3
FLS 1	Fail-safe 1	Set relay 1-8 fail-safe operation	unLoc	Unlocked	Program password to lock scanner
on	On	Enable fail-safe operation	Locd	Locked	Enter password to unlock scanner
OFF	Off	Disable fail-safe operation	999999 -999999	Flashing	Over/under range condition
dELRY	Delay	Enter relay Time Delay menu			
dLY 1*	Delay 1*	*Enter relay 1-8 time delay setup			
On 1	On 1	Set relay 1 On time delay			
OFF 1	Off 1	Set relay 1 Off time delay			
brERH	Break	Set relay condition if communication break detected			
no Rct	No action	Ignore break condition. No change in relay state when Communications Break detected.			
On	On	Relay goes to alarm condition when break detected. Relay turns on when Communications Break detected.			

## ScanView Software

The meter can also be programmed using the PC-based ScanView software included with the meter. This software is can be installed on any Microsoft® Windows® (XP/Vista/7/8/10) computer by connecting to the meter's onboard USB. The meter is powered by the USB connection, so there is no need to wire anything prior to programming the meter, though USB is intended only for meter configuration.

### ScanView Installation

1. Connect one end of the provided USB cable to the meter and the other end to the computer. The computer will automatically install the driver software it needs to talk to the meter.

**Only one meter may be connected at a time. Attaching multiple meters will cause a conflict with the meter software.**

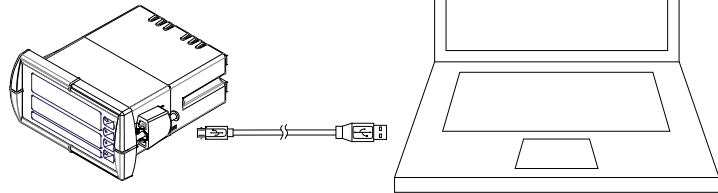

2. Once the driver is installed, an AutoPlay dialog should appear for the drive "MSINSTALL." Click "Open folder to view files." If the computer does not display an AutoPlay dialog for the drive "MSINSTALL," you should open *My Computer* and double-click on the drive labeled "MSINSTALL."
3. Double-click on the file named "MSStart." The program will open a few windows and install two programs on your computer. Simply follow the onscreen instructions until you see one of the dialogs below. If you receive a "User Account Control" warning, click "Yes."
4. If there is an update available, click the "Update" button to install the new version. Otherwise, click "Configure" to begin programming your meter.

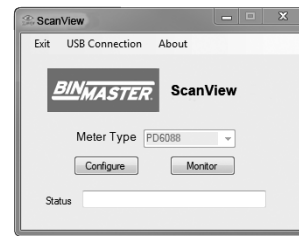
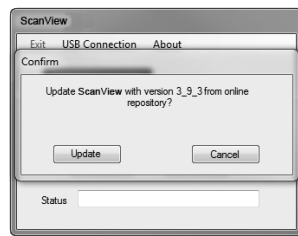
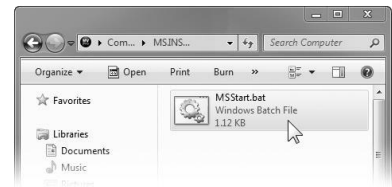

**Note:** If you decide to update your ScanView installation, once the installation has completed, you will be asked if you want to update the installation files located on the meter itself. This way, you will always have the most current installation version on the meter for future installs.

 <b>Warning!</b>	<ul style="list-style-type: none"> <li>• <b>Do not unplug the meter while the new installation files are being written to it. The meter will display <math>\overline{u}</math> <math>\overline{r}</math> <math>\overline{tE}</math> during the process and you will receive an onscreen notification once the process is complete.</b></li> <li>• <b>Do not disconnect and reconnect the meter rapidly. Allow at least 10 seconds from disconnection before reconnecting USB to the meter.</b></li> </ul>
---------------------	---

Monitoring and data logging for one scanner (Master mode) is available with ScanView software. All the enabled PVs and math channels may be logged to a single .csv file. The ScanView software synchronizes with the scanner in *master* mode one second after the scanner has completed a polling cycle.

*Note: The poll time of the scanner must be greater than 5 seconds to prevent collisions on the bus.*

### Menu Navigation Tip

- The Up arrow scrolls through the sub-menus within a menu, after the last item it returns to the top menu. Press Enter to step into the menu again or press Up arrow to move to the next menu. Note: There are some exceptions (e.g. PV - Enable - - Data type ▲ Next PV).
- Press Menu to exit programming at any time.

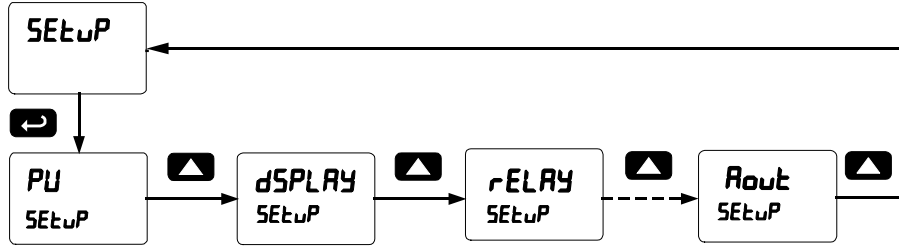

### Setting Numeric Values

The numeric values are set using the Right and Up arrow buttons. Press the Right arrow to select the next digit and the Up arrow to increment the digit's value. The digit being changed is displayed brighter than the rest. Press and hold the Up arrow to auto-increment the display value. Press the Enter button, at any time, to accept a setting or the Menu button to exit without saving changes.

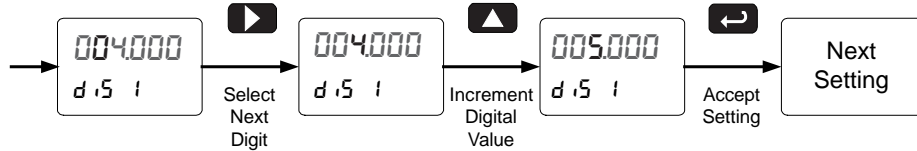

### Main Menu

The main menu consists of the most commonly used functions: *Mode*, *Setup*, *Serial*, and *Password*.

- Press Menu button to enter Scanner Programming
- Press Up arrow button to scroll through the menus
- Press Menu, at any time, to exit and return to Run Mode
- Changes to the settings are saved to memory only after pressing Enter
- The display moves to the next menu every time a setting is accepted by pressing Enter

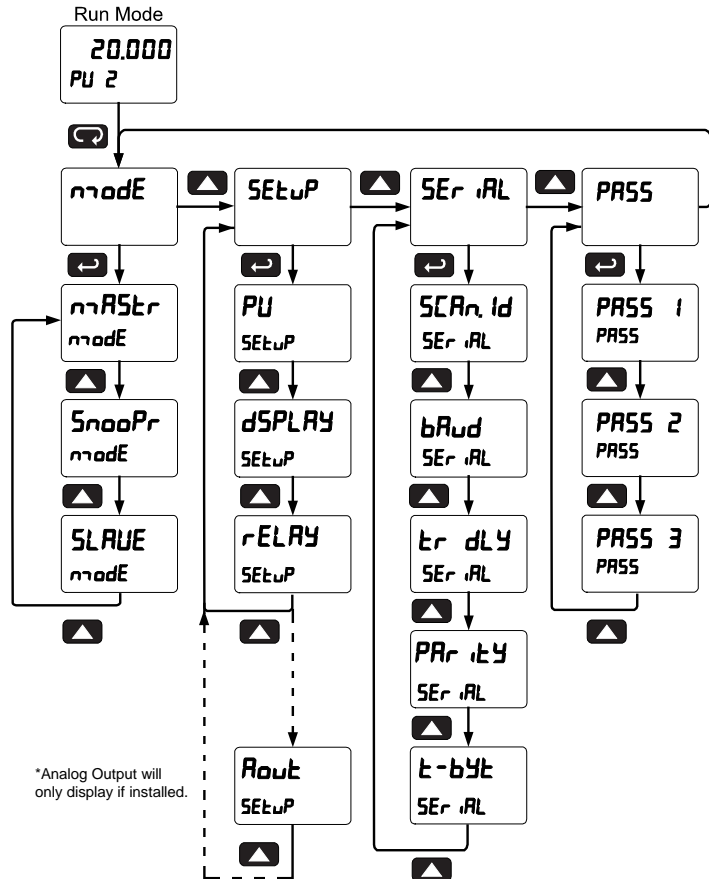

## Serial Communications (SEr iAL)

The scanner is equipped with RS-485 Modbus RTU serial communications.

The *Serial* menu is used for programming the Scanner ID, Baud Rate, Transmit Delay, Parity, and Byte-to-Byte Timeout parameters.

The meter may be connected to a PC for initial configuration via the onboard micro USB connection. For ongoing digital communications with a computer or other data terminal equipment, an RS-232, or RS-485 option is required; see *Ordering Information* on page 6 for details.



**Warning!** *Do not connect any equipment other than BinMaster's expansion modules, cables, or scanners to the RJ45 M-LINK connector. Otherwise damage will occur to the equipment and the scanner.*

When using more than one scanner in a multi-drop mode, each scanner must be provided with its own unique address. The scanner address (Scan ID) may be programmed between 1 and 247.

The transmit delay may be set between 0 and 4999 ms; this value must be less than (Poll Time/# of PVs).

The parity can be set to even, odd, or none with 1 or 2 stop bits.

Changes made to the Serial menu are initialized after exiting the Serial menu.

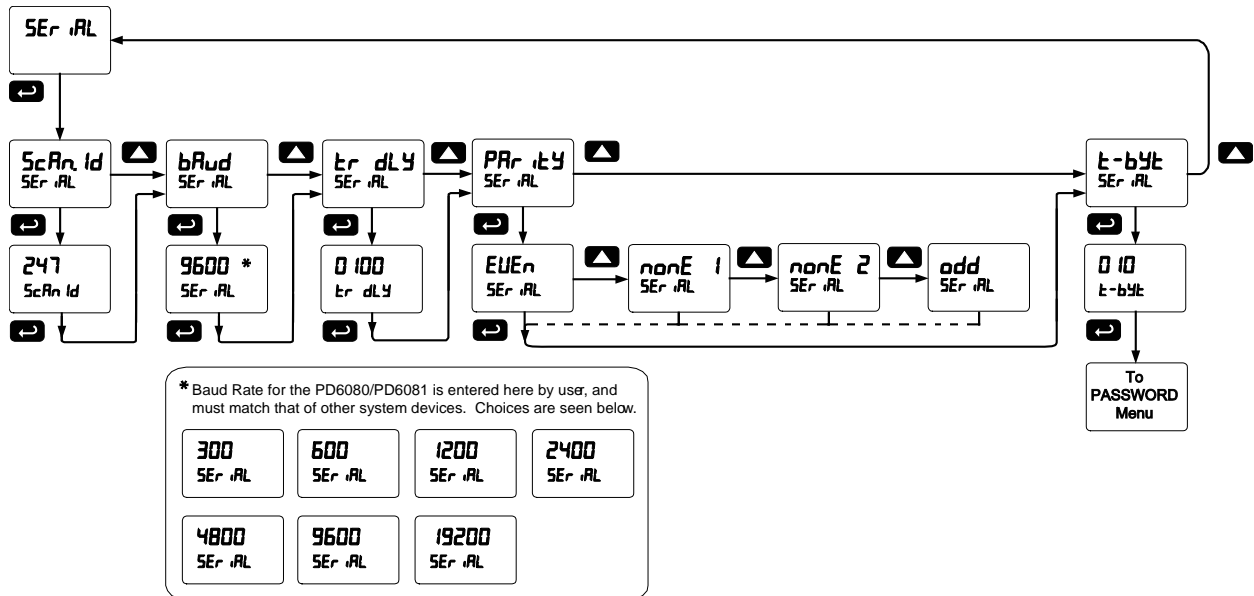

When setting up the scanner to run on a Modbus system, the devices must be programmed with matching Baud Rate and Parity. Failure to match up the network devices' parameters may result in communication breaks.

**Notes:**

1. *The byte-to-byte timeout setting may be adjusted to fix communication errors with slow devices.*
2. *The Transmit Delay of the Master must be greater than the Snooper or the slave devices being polled.*
3. *When using the M-Link to connect to a Modbus network, the DPM-100 cannot be used as a Master, but can be used as a Snooper or as a Slave. In order to use the DPM-100 as a Master, the scanner must connect to the Modbus Network via the three-wire terminal connector on the back of the scanner.*



## Scanner Mode Selection

### Operating Modes (mode)

The *Mode* menu is used to select how the scanner is to function:

1. Master: Reads a slave device, scales the data from it, displays the result, and operates the relays and 4-20 mA output. The Master polls from 1 to 16 process variables from 1 to 16 slave devices. The Master processes and displays PV1 through PV16 and alternately displays the variables being polled.
2. Snooper: Listens to the Modbus traffic and picks up a specific register or registers being polled by a Master device from a specific slave device and processes the data being read.
3. Slave: Read and controlled by a master device (PLC, DCS, etc). The data sent to it by the master is scaled, displayed, and used to operate the relays and 4-20 mA output.

The Master mode requires additional parameter selection to specify how the slave device is to be read and how to interpret the data.

Press **Menu** to enter Scanner Programming. Press the **Enter** button to access any menu or press **Up** arrow button to scroll through choices. Press the **Menu** button to exit at any time and return to Run mode.

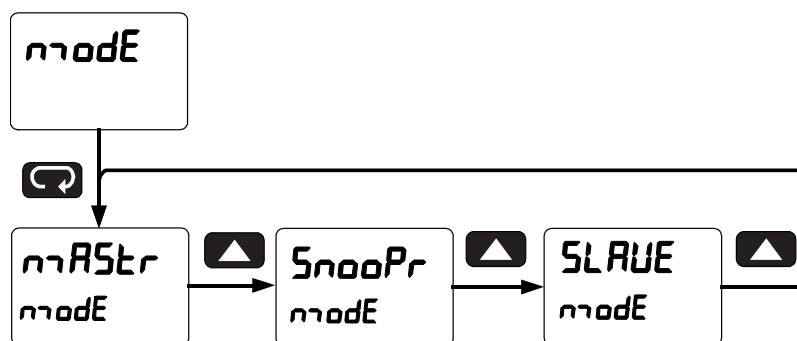

### How to Enable Process Variables (PVs)

In Master or Snooper Mode, navigate to the *PV Number* menu and press ENTER. From there, the user can scroll through all of the sixteen available PVs. In order to enable a specific PV, simply press ENTER to access the desired PV, then scroll to ENABLE and press ENTER (Follow the same course of action for disabling PVs).

Enter the Slave ID of the device being polled by the Master, followed by the Function Code, Register Number, Data Type, and Byte Order.

Once the desired PVs are enabled, navigate to the *Setup* menu and enter the PV Setup in order to select the PV tag, units, format, and decimal point parameters, as well as to scale the PVs.

Once the user has scaled the final PV, the scanner automatically goes to the *Display Setup* menu to access line 1 and 2 display assignments.

By default, display line 1 is assigned to *Display PV (d PU)* and line 2 to display the *Tag (d TAG)* for the corresponding PV.

It is possible to display PVs & Tags on line 1 and 2 simultaneously by selecting *Tag & PV Number (TAGPVn)*. Display line 1 is setup by default to display PV & tag for PV1, 3, 5, 7; while line 2 is setup by default to display PV & tag 2, 4, 6, 8. These can be changed by the user to display any or all PVs. Program either display line 1 or 2 to show the desired parameters and press ENTER. See page 32 for details.

### Master Mode (mAStr)

The Master mode contains the *PV Number*, *Poll Time*, and *Response Timeout* menus.

*PV Number*: Enable/disable PVs, select slave ID, function code, register number, data type & byte order.

*Poll Time*: Enter the time interval to poll the slave devices selected.

*Response timeout*: Enter the time interval to wait after three polls before reporting it as a Communications Break.

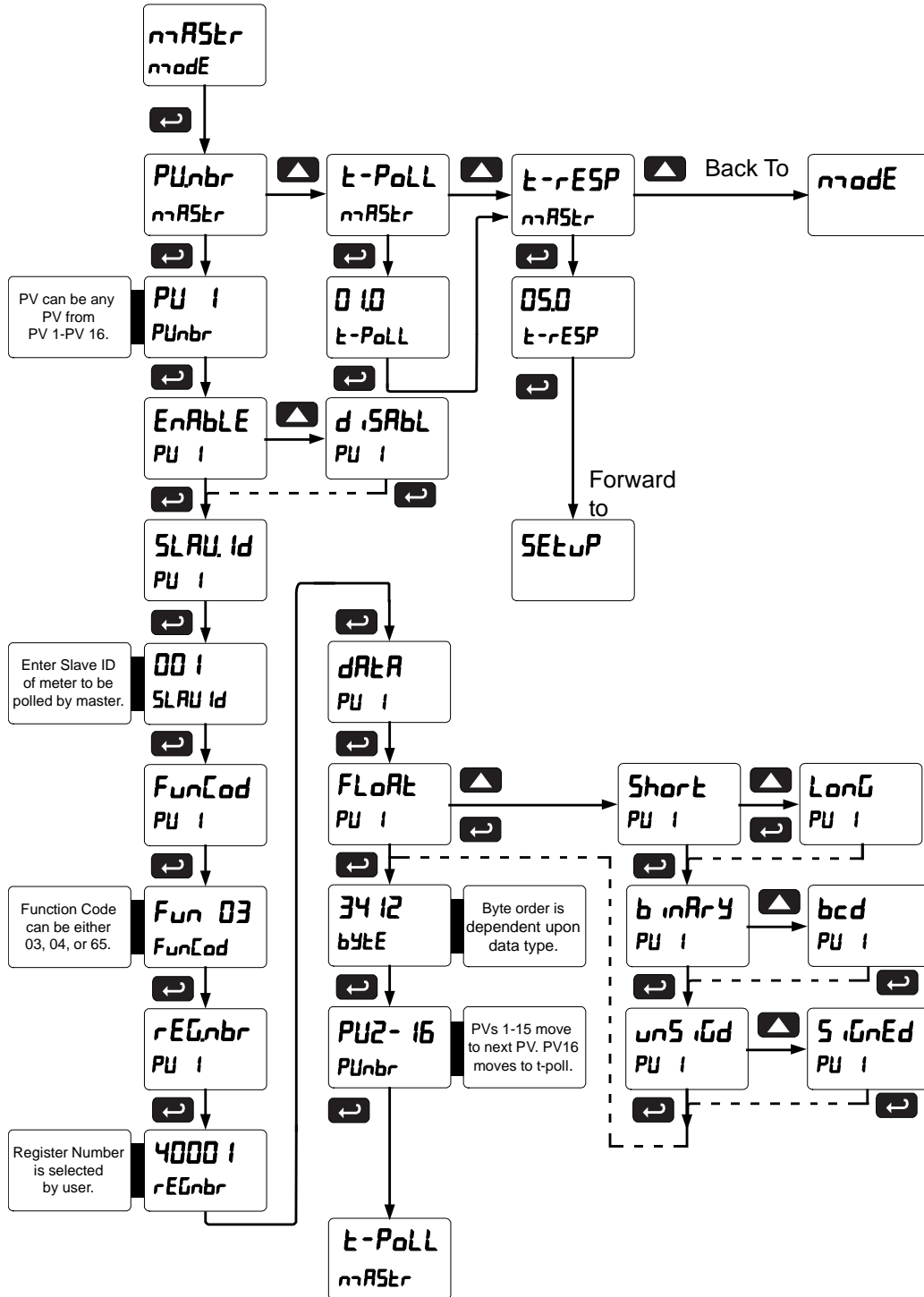

### Snooper Mode (SnooPr)

The Snooper mode is used to listen to data being transmitted on the bus. Multiple Snoopers can be connected to the RS-485 bus and display any process variable. The same process variable can be displayed in multiple locations. Use the menu below to configure Snooper Mode parameters.

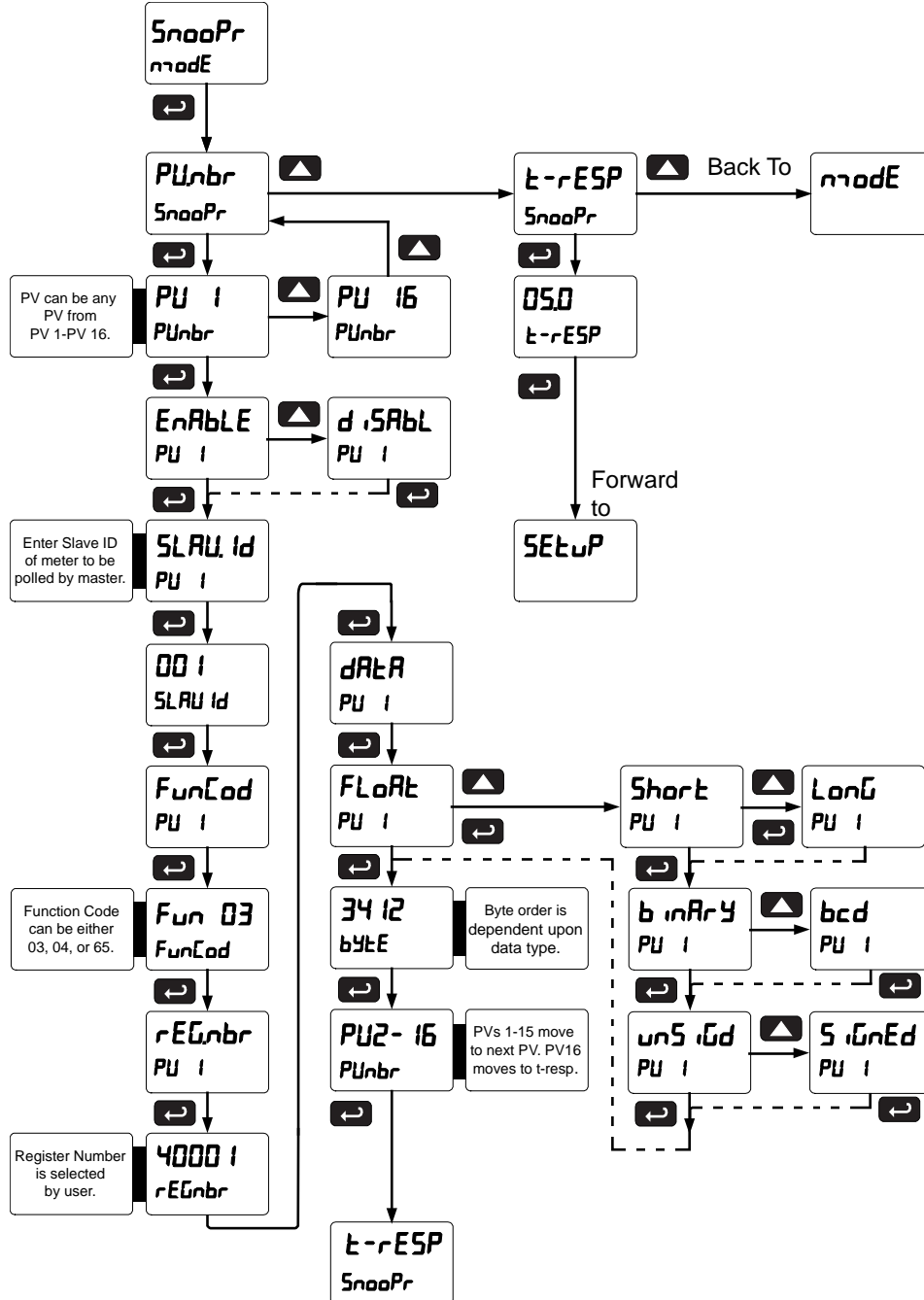

**Notes:**

1. To minimize the possibility of communication errors and communication break conditions, use a poll time of 5 seconds or more with slow baud rates (e.g. 4800 bps or less).
2. The response time for scanners set up for Snooper mode must be greater than the Master's poll time. This setting corresponds to the time window during which the Snooper listens to the bus for a reply by the slave device being polled by the master device. As soon as the Snooper detects a new reply on the bus, the display is updated. If there is no reply within the response time setting, the Snooper goes into communications break condition.

## How to Select 5 or 6-Digit Registers

In Master or Snooper Mode, it is possible to select either a five-digit or a six-digit Register Number. Once the operator has enabled a PV, entered a Slave ID, and chosen a Function Code, the scanner will arrive at the Register Number menu (**rEGnbr**). Press the Right arrow to display and then the Up arrow to change the setting for the number of digits used for the Register Number (**5 d iG** or **6 d iG**), then press ENTER.

Notes:

1. If Function Code 03 is selected, the Register Number defaults to 40001; if Function Code 04 is selected, the Register Number defaults to 30001.
2. Default Data Type is Float
3. Default Slave ID for PV1=001, for PV2=002, for PV3=003, etc.

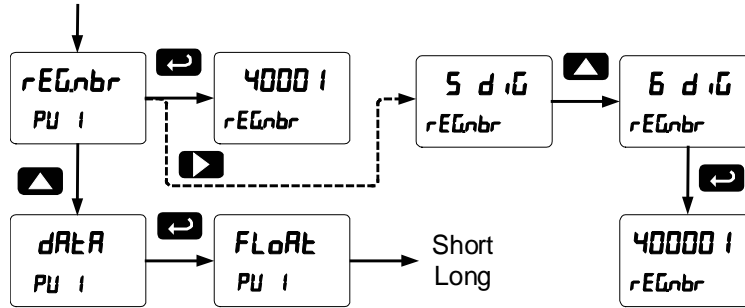

The Master ignores the decimal point setting for slave devices that specify a Short or Long integer. For example, a slave that is displaying 12.34 is read as 1,234. Floating point data may or may not utilize the decimal point. Refer to the slave's operating manual to make sure.

The Register Number range is based on the Function Code and the number of digits selected. See the following table:

Function Code	5 Digit	6 Digit
03	40001 – 49999	400001 – 465536
04	30001 – 39999	300001 – 365536
65	65001-65999	N/A

## Slave Mode (SLAVE)

The Slave mode is capable of accepting Short, Long, and Float data types. Refer to the Modbus Register Tables at [www.binmaster.com](http://www.binmaster.com) for details of all the predefined parameters. Follow the menu below to navigate and set all parameters for Slave Mode.

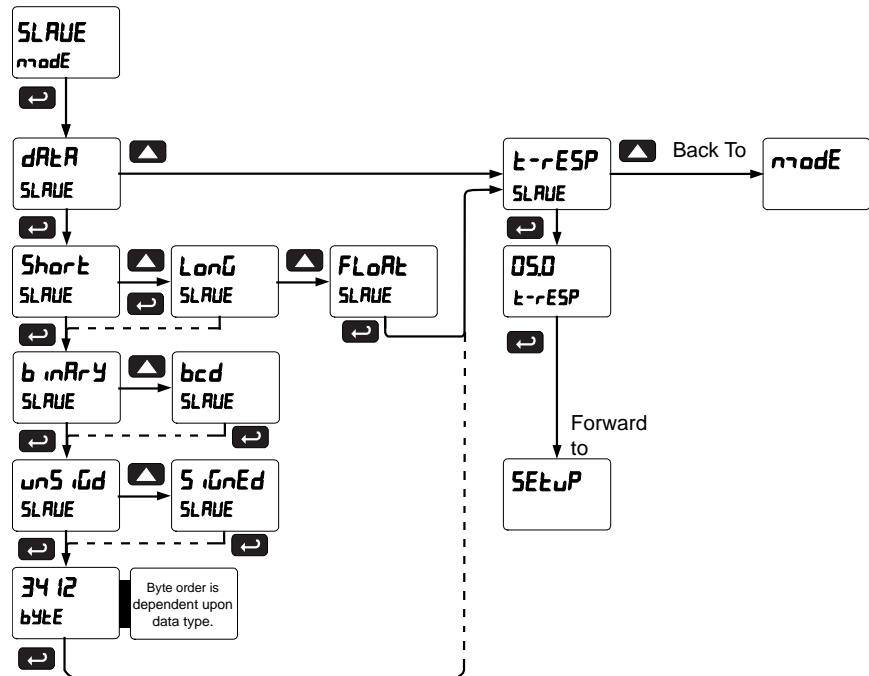

## Setting Up the Scanner (SEtUP)

The *Setup* menu is used to select:

1. PV Setup
  - a. PV Tags
  - b. PV Units
  - c. Format: Decimal point or Feet & Inches
  - d. Decimal Point
  - e. Scale input data
2. Display assignment & Intensity
3. Relay assignment and operation
4. 4-20 mA analog output scaling

Press the Menu button to exit at any time.

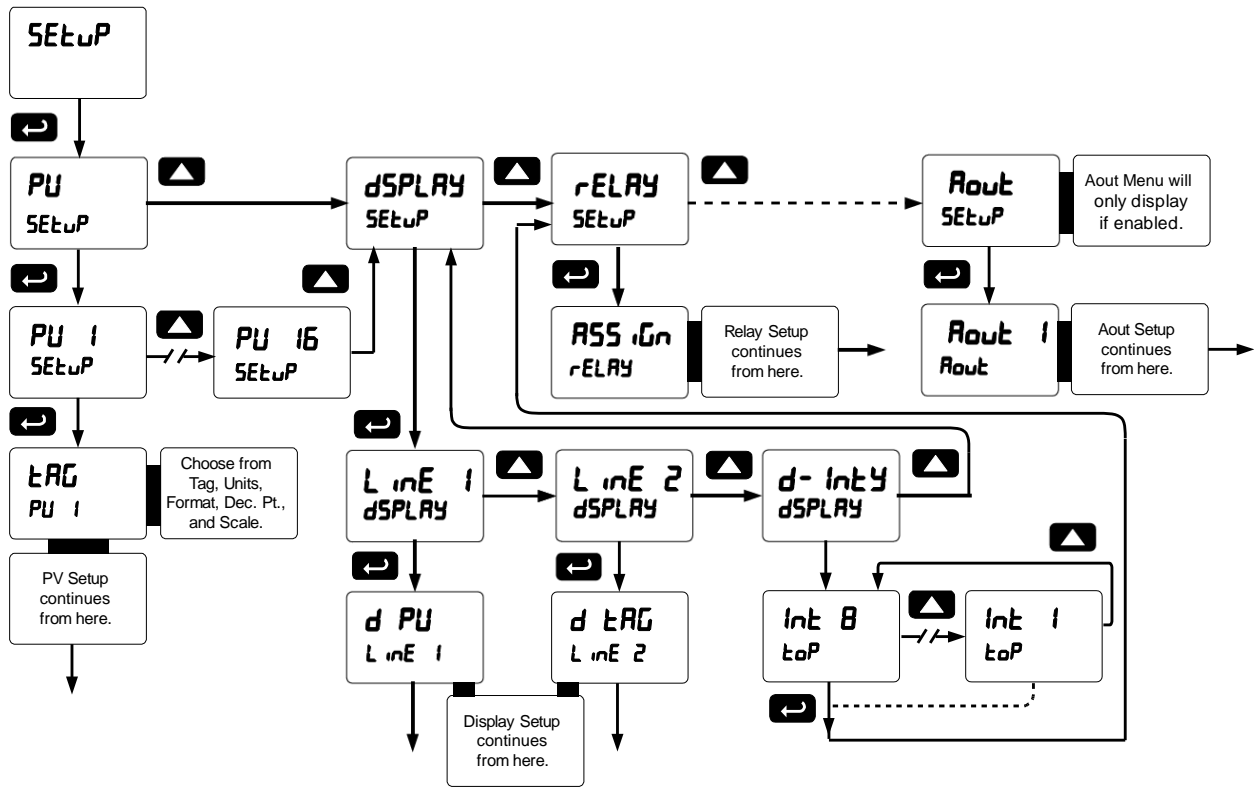

### Setting Up the Process Variables (PVs) (PU Setup)

Enter the *PV Setup* menu to set up all the criteria associated with each enabled PV. Once you have selected the desired PV, you can select parameters for each. These include tag, units, format, display decimal point, float decimal point (resolution), and scaling of the input data.

*Note: PV1 and PV2 can have multiple points for linearization. Only two points are available for all other PVs and for either the Square Root or Programmable Exponent functions.*

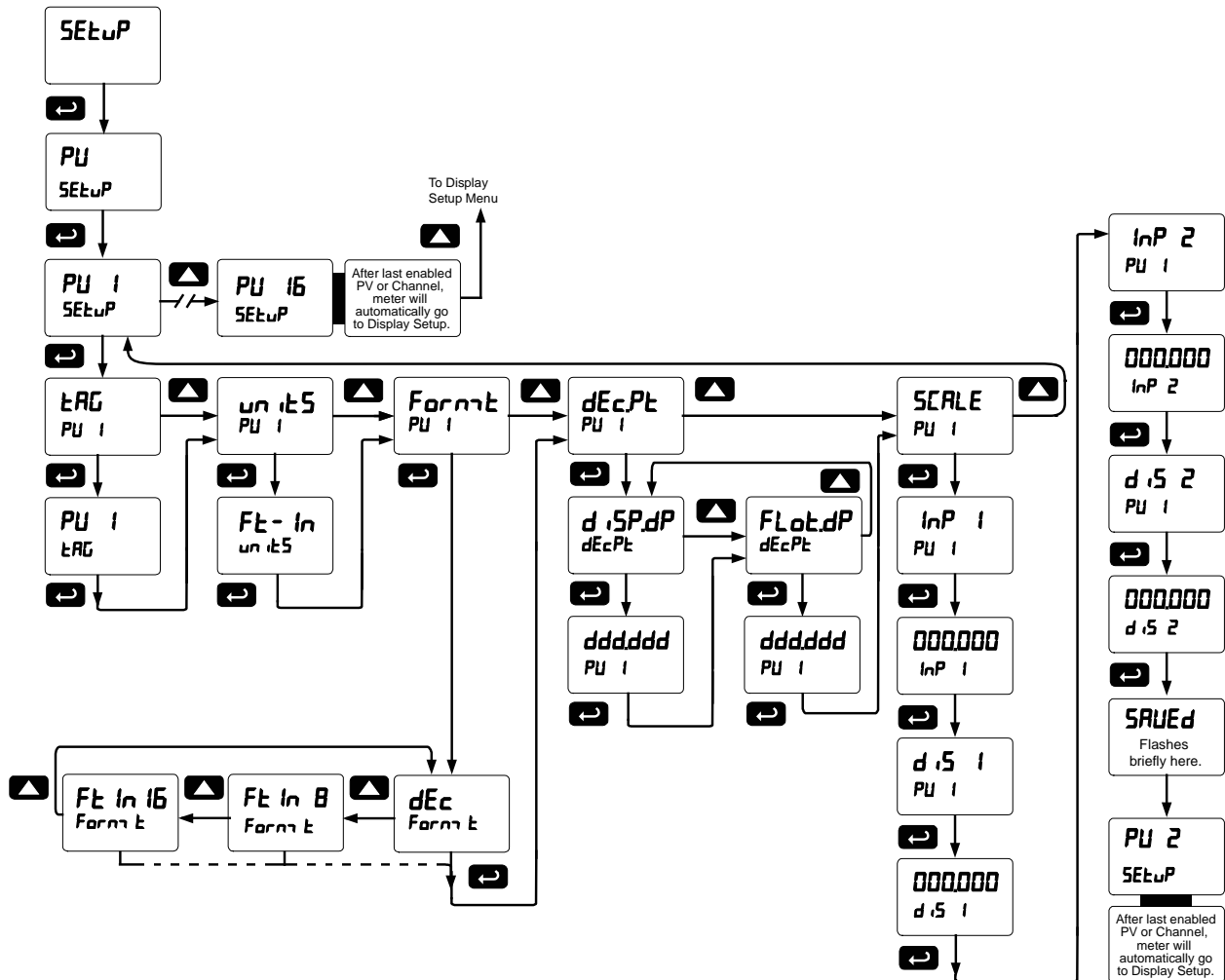

### Setting the Display Decimal Point (d ISP.dP)

Decimal point may be set one to five decimal places or with no decimal point at all. Pressing the **Up** arrow moves the decimal point one place to the right until no decimal point is displayed, and then it moves to the leftmost position. The decimal point is programmable only for the Display Value.

### Setting the Float Decimal Point (FLot.dP)

If floating point data type is selected, select the number of decimals to correspond to the expected floating-point data; the numbers to right of the LSD will be ignored by the scanner.

Example:

If you have a number such as 12.3456, you have to tell the scanner how many digits to the right are of interest to you. In this case selecting 4 places will make use of all the digits. For most applications the display decimal point will be set accordingly (*i.e.* 4 places).

If 2 decimal places are selected, the number 12.3456 is displayed as 12.35; notice that the number is rounded up.

## Scaling the PV Display Values (SCALE)

The data that the scanner receives can be scaled to display in engineering units. Input 1 must be less than Input 2; Input 2 must be less than Input 3; etc. (known as monotonic values). Press **Enter** to save the changes or **Menu** to exit without saving. When the Linear function is selected for PV1 & PV2, up to 32 points may be programmed to handle non-linear data. Only two points are available for all other PVs and for either the Square Root or Programmable Exponent functions. Round Horizontal Tanks are scaled using the length and diameter of the tank.

### Scale Menu

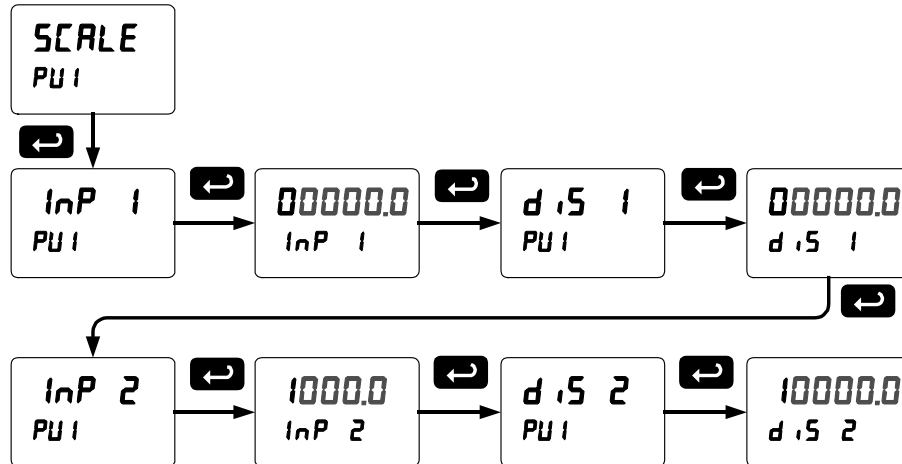

The display will show **Error** if the scaling process is unsuccessful. Undesired operation may occur if the error is not corrected. Correct the error by either changing one of the inputs in question or changing the number of points to exclude an erroneous input point.

*Note: Scaling Short and Long input values (input 1, input 2, etc.) should be done without the decimal point.*

### Multi-Point Linearization (L inErr)

The scanner is set up at the factory for 2-point linear scaling. Up to 32 linearization points may be selected for PV1 and PV2. All other PVs have two linearization points available. See page 56 for details.

## Setting Up the Displays (*d5PLAY 5EUP*)

### Line 1 Parameters (*L nE 1 d5PLAY*)

The top display (*L nE 1*) can be programmed to display any of the following:

Display	Parameter	Setting Description
<i>d PV</i>	<i>Display PV</i>	Display PVs 1-16
<i>d Ch-C</i>	<i>Display C Channel</i>	Display Math Channels C1-C4
<i>PV and U</i>	<i>Display PV &amp; Units</i>	Display PV & Units
<i>Tag, PV#</i>	<i>Display Tag, PV Number</i>	Display Tag & PV Number selected
<i>Tag, PV#, U</i>	<i>Display Tag, PV# &amp; Units</i>	Display Tag, PV Number selected, & Units
<i>C and U</i>	<i>Display C &amp; Units</i>	Display C1-C4 & Units
<i>Tag, C, U</i>	<i>Display Tag, C, &amp; Units</i>	Display Tag, C1-C4 & Units
<i>dSEt 1-8</i>	<i>Display Set Points 1-8</i>	Display Set Points 1-8
<i>H i-PV</i>	<i>Display Max PV 1-16</i>	Display Maximum value for each enabled PV1-16
<i>Lo-PV</i>	<i>Display Min PV 1-16</i>	Display Minimum value for each enabled PV1-16
<i>H i-C</i>	<i>Display Max Ch C1-C4</i>	Display Maximum for math channels C1-C4
<i>Lo-C</i>	<i>Display Min Ch C1-C4</i>	Display Minimum for math channels C1-C4

### Line 2 Parameters (*L nE 2 d5PLAY*)

The bottom display (*L nE 2*) can be programmed to display any of the following:

Display	Parameter	Setting Description
<i>d PV</i>	<i>Display PV</i>	Display PVs 1-16
<i>d Ch-C</i>	<i>Display C Channel</i>	Display Math Channels C1-C4
<i>PV and U</i>	<i>Display PV &amp; Units</i>	Display PV & Units
<i>Tag, PV#</i>	<i>Display Tag, PV Number</i>	Display Tag & PV Number selected
<i>Tag, PV#, U</i>	<i>Display Tag, PV# &amp; Units</i>	Display Tag, PV Number selected, & Units
<i>C and U</i>	<i>Display C &amp; Units</i>	Display C1-C4 & Units
<i>Tag, C, U</i>	<i>Display Tag, C, &amp; Units</i>	Display Tag, C1-C4 & Units
<i>dSEt 1-8</i>	<i>Display Set Points 1-8</i>	Display Set Points 1-8
<i>H i-PV</i>	<i>Display Max PV 1-16</i>	Display Maximum value for each enabled PV1-16
<i>Lo-PV</i>	<i>Display Min PV 1-16</i>	Display Minimum value for each enabled PV1-16
<i>H i-C</i>	<i>Display Max Ch C1-C4</i>	Display Maximum for math channels C1-C4
<i>Lo-C</i>	<i>Display Min Ch C1-C4</i>	Display Minimum for math channels C1-C4
<i>d Tag</i>	<i>Display Tag</i>	Display Tag (Line 2 only)
<i>d Tag, U</i>	<i>Display Tag &amp; Units</i>	Display Tag & Units (Line 2 only)
<i>d oFF</i>	<i>Display off</i>	Display Off (Line 2 only)

*Note: Toggling displays use the Scan Time for the value and 2 seconds for Tag and Units.*

### Display Intensity (*d- IntY*)

The scanner has eight display intensity levels to give the best performance under various lighting conditions. Select intensity 8 for outdoor applications. The default intensity setting is 8.



Display Line 1 Menu (Line 1 dSPAY)

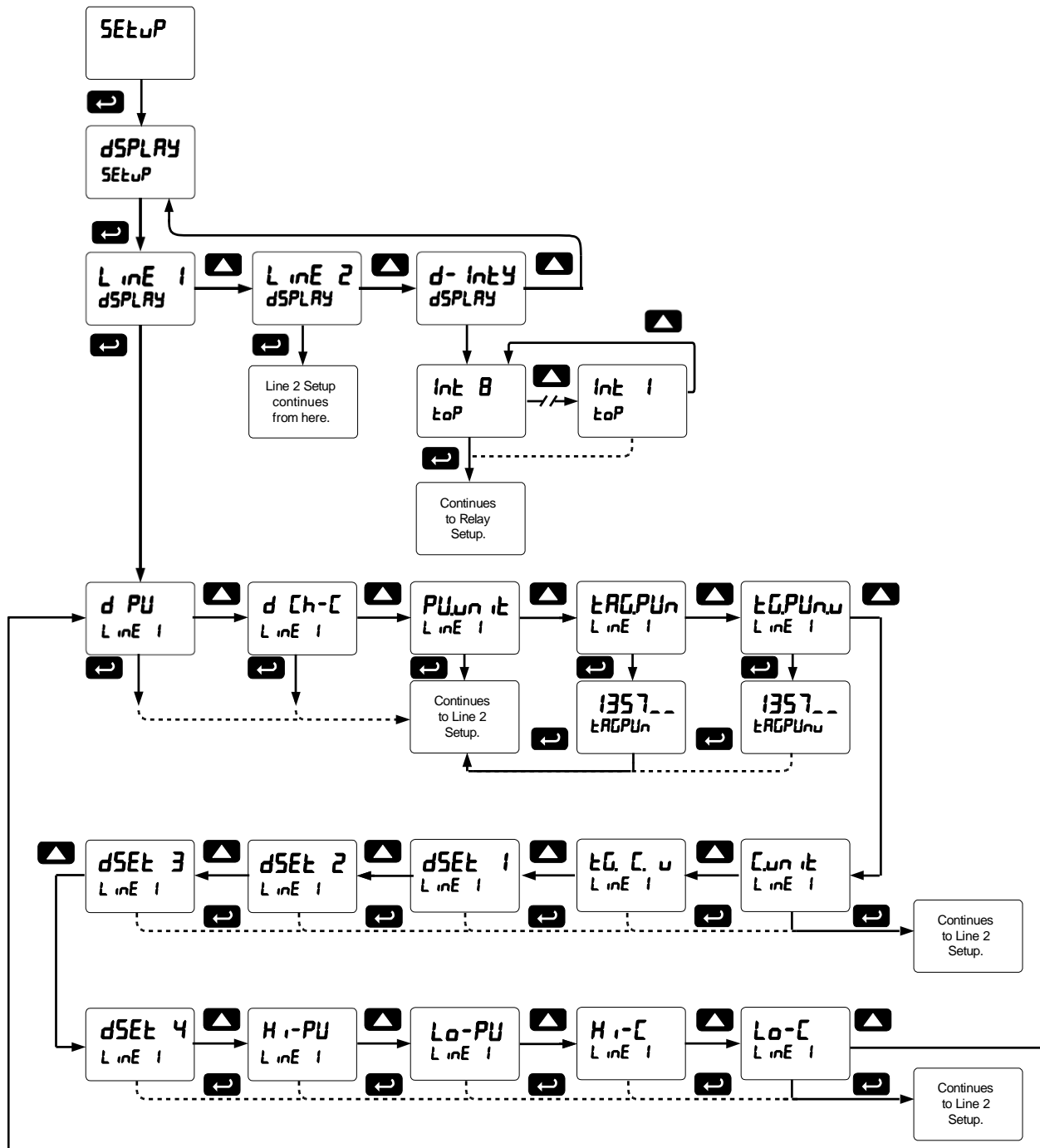

Note: For Tag-PVn and Tag-PVn-U, the default settings for PVs are 1,3,5,&7, followed by two underscores, which represent empty PVs. These all can be changed to any enabled PVs.

Display Line 2 Menu (LINE 2 dSPRAY)

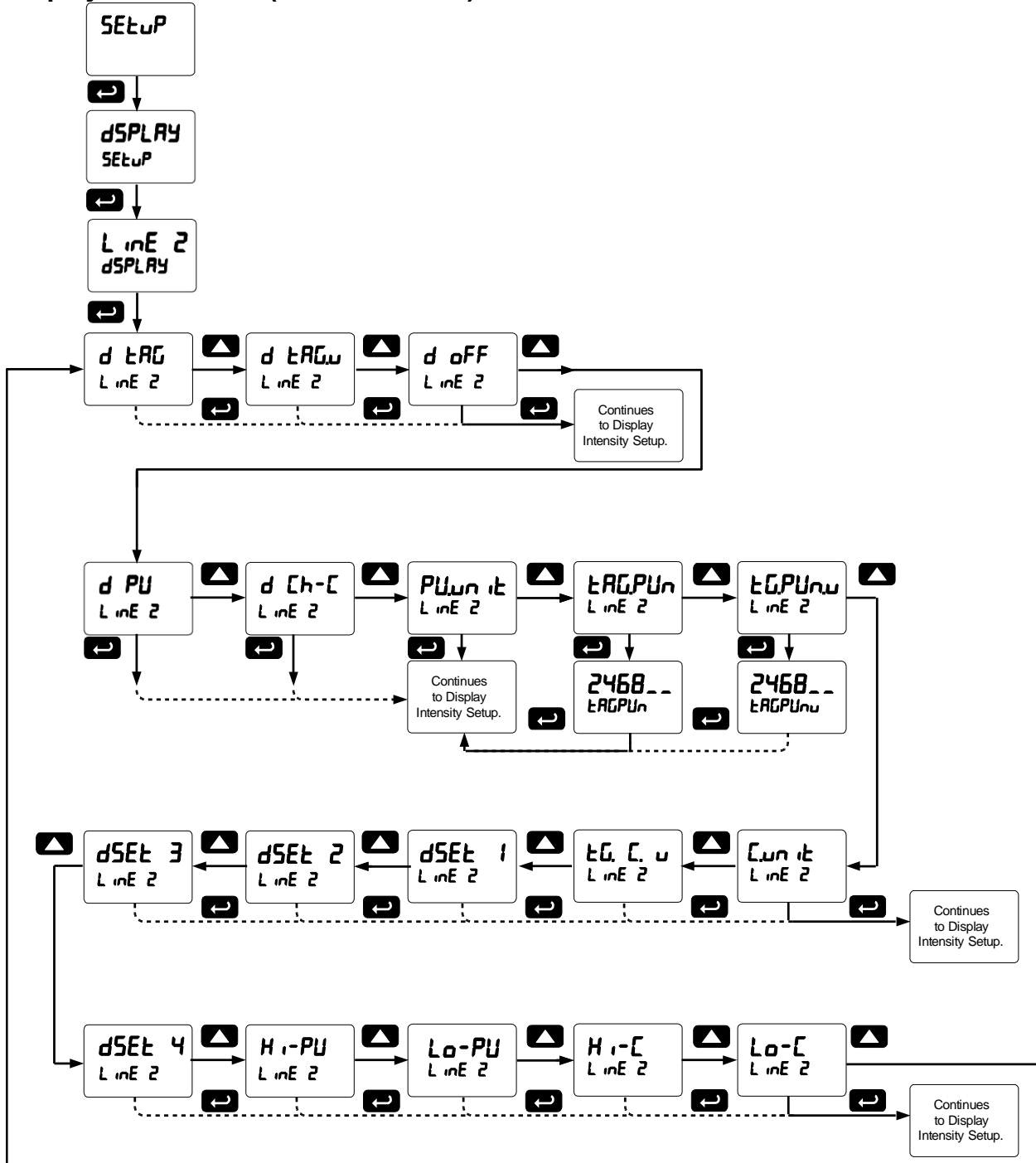

Note: For Tag-PVn and Tag-PVn-U, the default settings for PVs are 2,4,6,& 8, followed by two underscores, which represent empty PVs. These all can be changed to any enabled PVs.

### Setting the Tags (TAG) & Units (UNIT)

Each PV can be setup with its own tag and units. See the flow charts on the previous pages to access the display menu to show the tag or toggling tag & units. The engineering units and custom tags can be set using the following 7-segment character set:

Display	Character	Display	Character	Display	Character	Display	Character
0	0	C	C	K	K	v	V
1	1	c	c	L	L	v v	w
2	2	d	d	m	m	X	X
3	3	E	E	n	n	Y	Y
4	4	F	F	O	O	Z	Z
5	5	G	G	o	o	-	-
6	6	g	g	P	P	/	/
7	7	H	H	q	q	[	]
8	8	h	h	r	r	]	[
9	9	i	i	S	S	=	=
A	A	l	l	t	t	°	Degree(<)
b	b	J	J	u	u		Space

Notes: Degree symbol represented by (<) if programming with ScanView. The letters “m” and “w” use two 7-segment LEDs each; when selected the characters to the right are shifted one position. Press and hold up arrow to auto-scroll the characters in the display.

### Application Example 1

In this application, we have a system consisting of (4) BinMaster NCR-80 multivariable tank level gauges connected to a DPM-100 displaying feet of product.

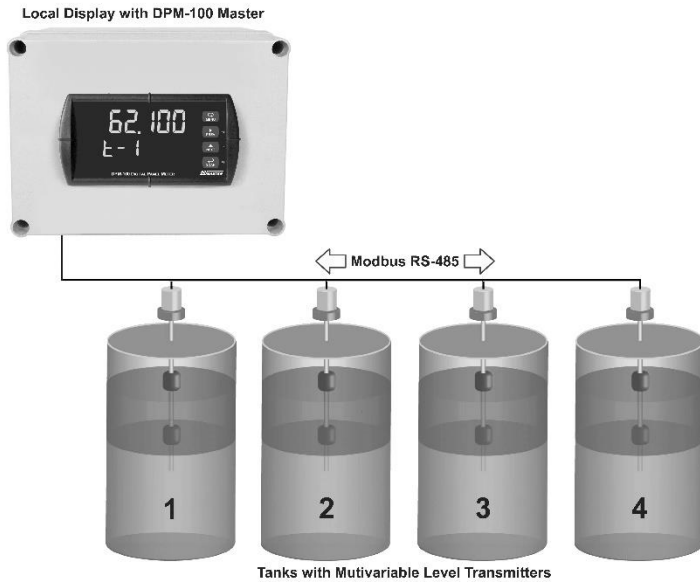

### Register Numbers & Process Variables

- 32003 – Feet of Product
- 32005 – Distance to Product (ft)
- 32007 – Linear Percent

The following table shows the system setup for the BinMaster NCR-80, one DPM-100 Master, and one DPM-100 Snooper:

Parameter	DPM-100	DPM-100	Description/Comment
Mode	Master	Snooper	
PV1 Slave ID	1	1	
Function Code	04	04	
Register PV1	32003	32003	Tank 1 Product Level in Feet
Data Type	Float	Float	
Byte Order	1234	1234	
PV2 Slave ID	1	1	
Function Code	04	04	
Register PV2	32005	32005	Tank 1 Distance to Product (ft)
Data Type	Float	Float	
Byte Order	1234	1234	
PV3 Slave ID	1	1	
Function Code	04	04	
Register PV3	32007	32007	Tank 1 Linear Percent
Data Type	Float	Float	
Byte Order	1234	1234	
PV4 Slave ID	2	2	
Function Code	04	04	
Register PV4	32003	32003	Tank 2 Product Level in Feet
Data Type	Float	Float	
Byte Order	1234	1234	
PV5 Slave ID	2	2	
Function Code	04	04	
Register PV5	32005	32005	Tank 2 Distance to Product (ft)
Data Type	Float	Float	
Byte Order	1234	1234	
PV6 Slave ID	2	2	
Function Code	04	04	
Register PV6	32007	32007	Tank 2 Linear Percent
Data Type	Float	Float	
Byte Order	1234	1234	
PV7 Slave ID	3	3	
Function Code	04	04	
Register PV7	32003	32003	Tank 3 Product Level in Feet
Data Type	Float	Float	
Byte Order	1234	1234	

Parameter	DPM-100	DPM-100	Description/Comment
PV8 Slave ID	3	3	
Function Code	04	04	
Register PV8	32005	32005	Tank 3 Distance to Product (ft)
Data Type	Float	Float	
Byte Order	1234	1234	
PV9 Slave ID	3	3	
Function Code	04	04	
Register PV9	32007	32007	Tank 3 Linear Percent
Data Type	Float	Float	
Byte Order	1234	1234	
PV10 Slave ID	4	4	
Function Code	04	04	
Register PV10	32003	32003	Tank 4 Product Level in Feet
Data Type	Float	Float	
Byte Order	1234	1234	
PV11 Slave ID	4	4	
Function Code	04	04	
Register PV11	32005	32005	Tank 4 Distance to Product (ft)
Data Type	Float	Float	
Byte Order	1234	1234	
PV12 Slave ID	4	4	
Function Code	04	04	
Register PV12	32007	32007	Tank 4 Linear Percent
Data Type	Float	Float	
Byte Order	1234	1234	
Scanner ID	246	245	
Polling Time	5.0 sec	N/A	
Slave Response Timeout	10.0 sec	10.0 sec	
Baud	9600	9600	
Parity	None 1	None 1	1 stop bit
Byte-to-Byte Timeout	0.01 sec	0.01 sec	
Decimal point	3 places	3 places	
Input 1	000000	000000	Scaling for Level & Interface
Display 1	000000	000000	
Input 2	999999	999999	0.001 inch resolution
Display 2	83.333	83.333	Feet

## Application Example 2

In this application, we have a system consisting of (4) BinMaster NCR-80 multivariable tank level gauges connected to a DPM-100 displaying feet of product, distance to product in feet, and linear percent. The display readout is shown in linear percent.

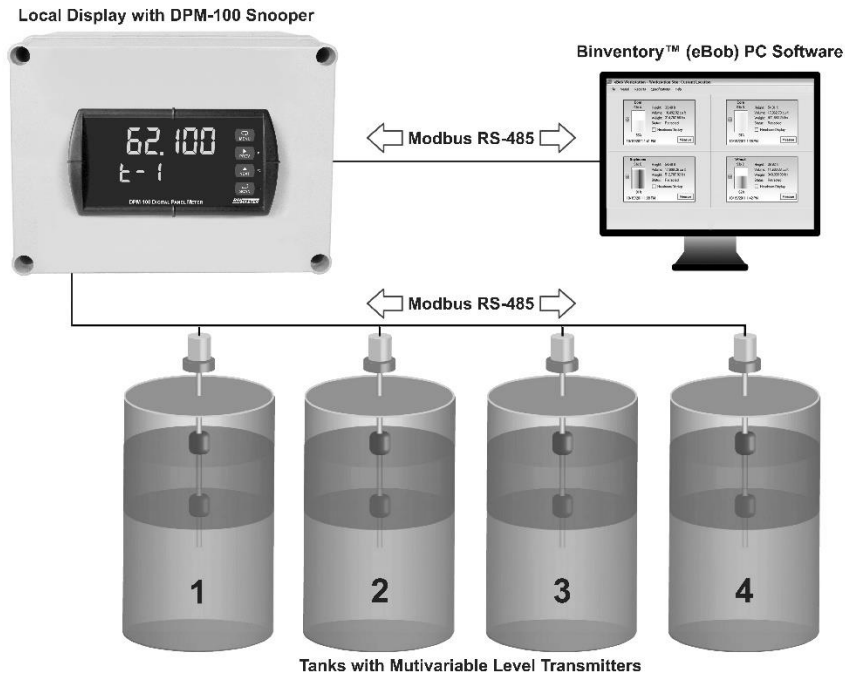

### Register Numbers & Process Variables

- 32003 – Feet of Product
- 32005 – Distance to Product (ft)
- 32007 – Linear Percent

## Setting the Relay Operation (rELAY)

This menu is used to set up the assignment and operation of the relays.

### Relay Setup Menu (rELAY SEtUP)

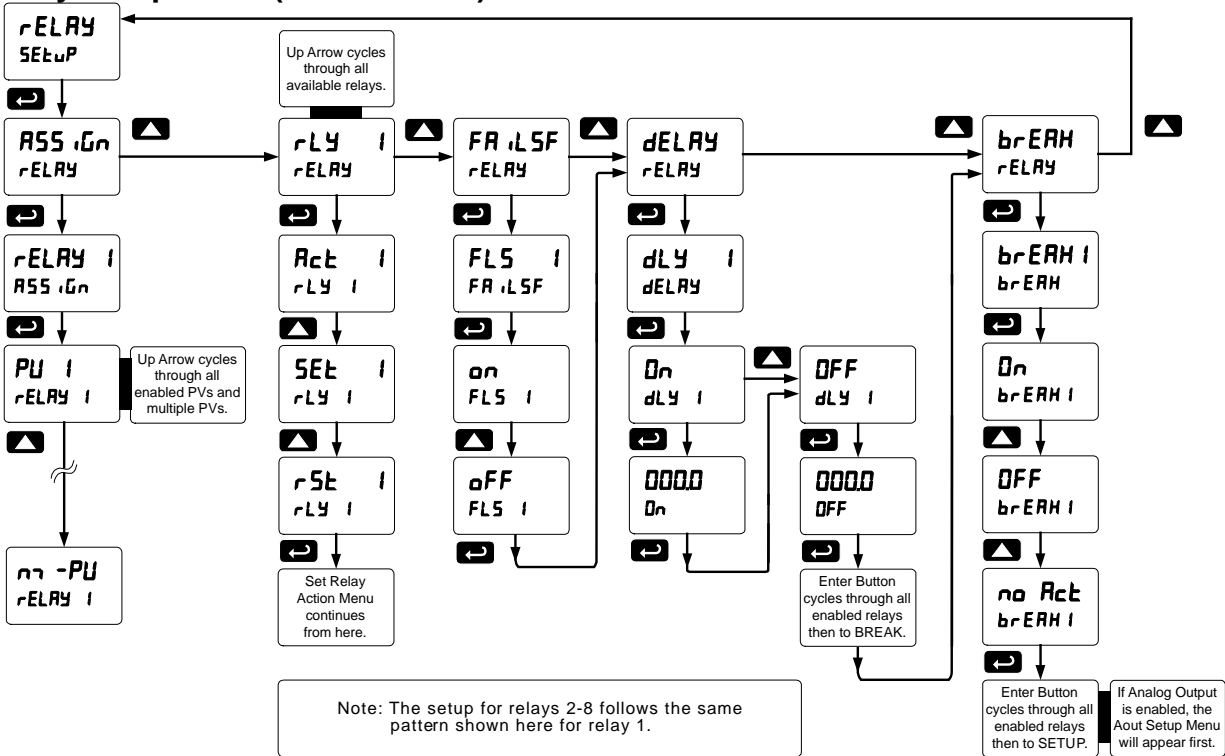

**Caution!** *During setup, the relays do not follow the input and they will remain in the state found prior to entering the Relay menu.*

1. **ASSIGN** Relay assignment
  - a. Assign relay to PV
  - b. Assign relay to Math channel
  - c. Assign relay to multiple PVs (2 to 16 PVs)
2. **Act 1** Relay action
  - a. Automatic reset only (non-latching)
  - b. Automatic + manual reset at any time (non-latching)
  - c. Latching (manual reset only)
  - d. Latching with Clear (manual reset only after alarm condition has cleared)
  - e. Pump alternation control (automatic reset only)
  - f. Sampling (the relay is activated for a user-specified time)
  - g. Off (relay state controlled by Interlock feature)
3. **SEt 1** Set point & **rSt 1** Reset point
4. **FAILSF** Fail-safe operation
  - a. On (enabled)
  - b. Off (disabled)
5. **dELAY** Time delay
  - a. On delay (0-999.9 seconds)
  - b. Off delay (0-999.9 seconds)
6. **brEAK** Relay action for communications break

### Setting the Relay Action (Act 1)

Operation of the relays is programmed in the *Action* menu. The relays may be set up for any of the following modes of operation:

1. **Auto** Automatic reset (non-latching)
2. **A-nnAn** Automatic + manual reset at any time (non-latching)
3. **LAtcH** Latching (manual reset only, at any time)
4. **Lt-CLr** Latching with Clear (manual reset only after alarm condition has cleared)
5. **ALtErn** Pump alternation control (automatic reset only)
6. **SA-nnPL** Sampling (the relay is activated for a user-specified time)
7. **oFF** Off (relay state controlled by Interlock feature)

The following graphic shows relay 1 action setup; relay 2-8 are set up in a similar fashion.

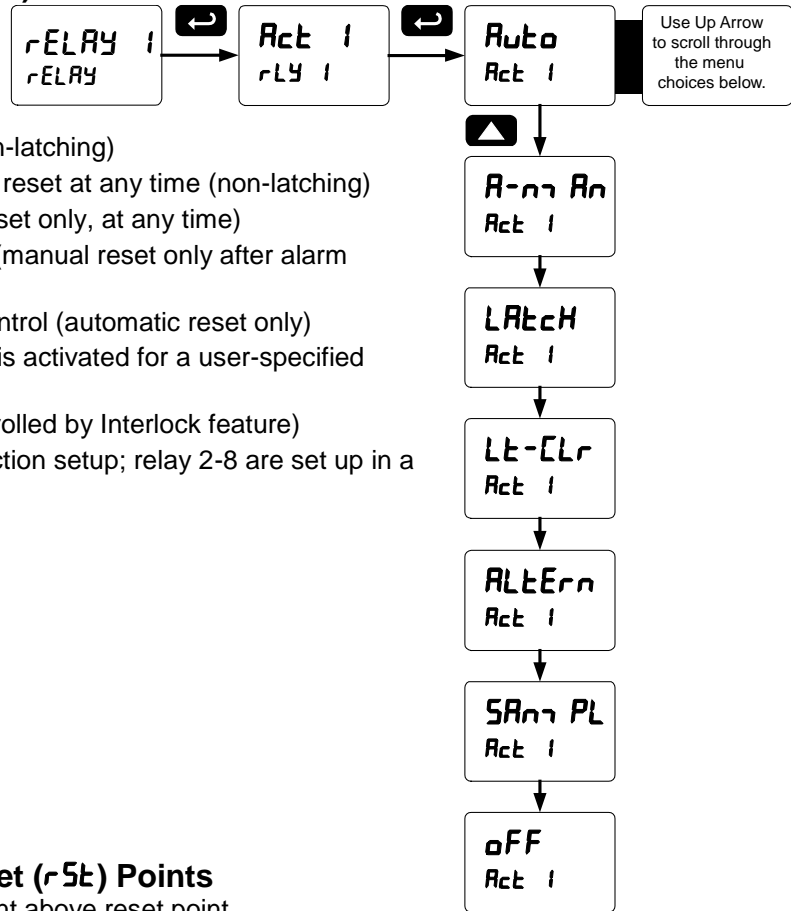

### Programming Set (SEt) & Reset (rSt) Points

High alarm indication: program set point above reset point.

Low alarm indication: program set point below reset point.

The deadband is defined as the difference between set and reset points. Minimum deadband is one display count. If the set and reset points are programmed with the same value, the relay will reset one count below the set point.

*Note: Changes are not saved until the reset point has been accepted.*

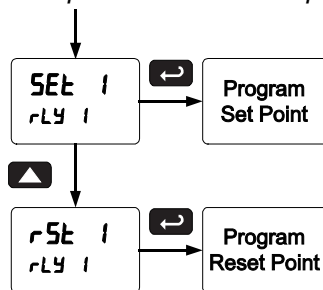

### Setting Fail-Safe Operation (FR LSF)

In fail-safe mode of operation, the relay coil is energized when the process variable is within safe limits and the relay coil is de-energized when the alarm condition exists. The fail-safe operation is set independently for each relay. Select **on** to enable or select **oFF** to disable fail-safe operation.

### Programming Time Delay (dELAY)

The *On* and *Off* time delays may be programmed for each relay between 0 and 999.9 seconds. The relays will transfer only after the condition has been maintained for the corresponding time delay.

The *On* time delay is associated with the set point.

The *Off* time delay is associated with the reset point.



### Relay Action for Communications Break (brERH)

The Scanner will poll the slave device three times before reporting a communications break condition. After the third failure, the Response Timeout timer starts and will determine the actual time to report a PV in break condition.

1. Turn On (Go to alarm condition)
2. Turn Off (Go to non-alarm condition)
3. No Action (The relays will maintain the last condition)

### Relay and Alarm Operation Diagrams

The following graphs illustrate the operation of the relays, status LEDs, and ACK button.

#### High Alarm Operation (Set > Reset)

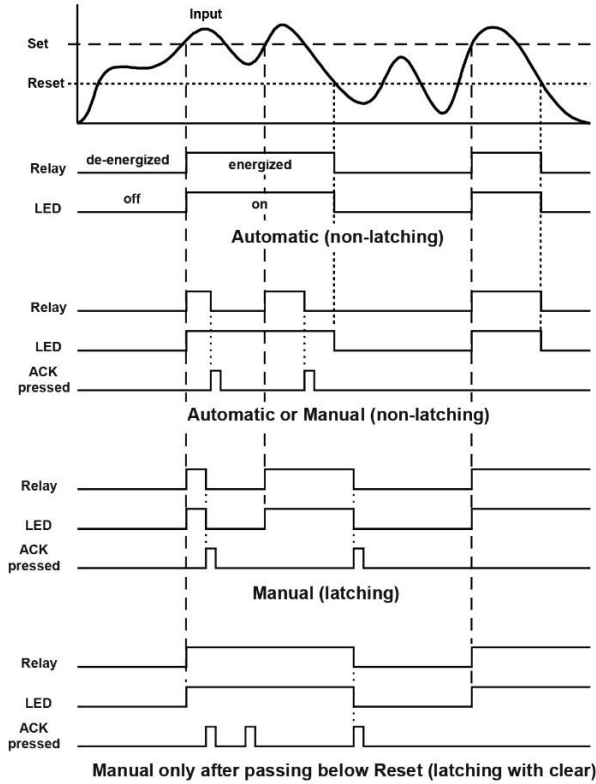

For Manual reset mode, ACK can be pressed anytime to turn "off" relay. To detect a new alarm condition, the signal must go below the set point, and then go above it.

#### Low Alarm Operation (Set < Reset)

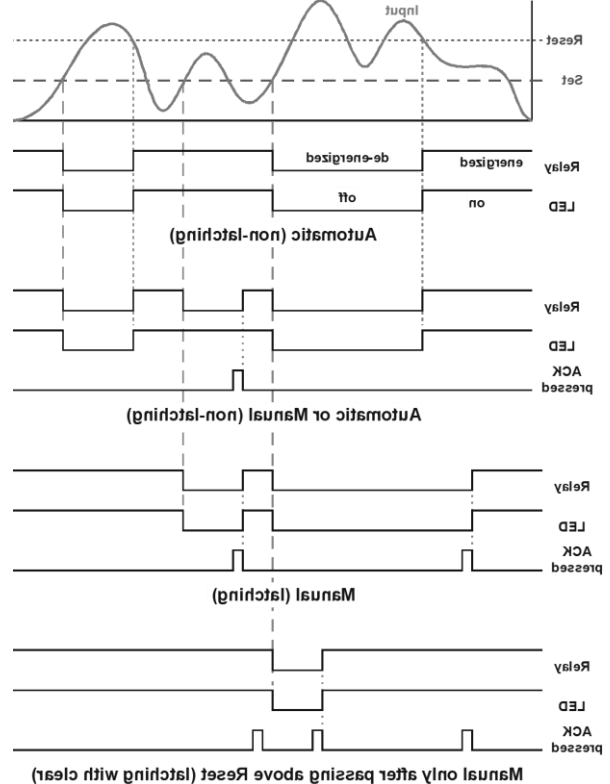

For Manual reset mode, ACK can be pressed anytime to turn "off" relay. For relay to turn back "on", signal must go above set point, and then go below it.

### High Alarm with Fail-Safe Operation (Set > Reset)

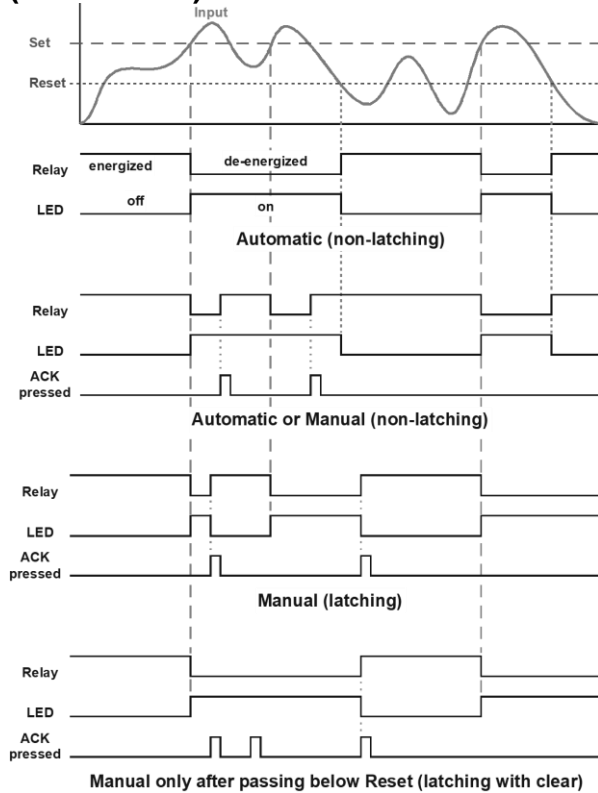

*Note: Relay coil is energized in non-alarm condition. In case of power failure, relay will go to alarm state.*

### Low Alarm with Fail-Safe Operation (Set < Reset)

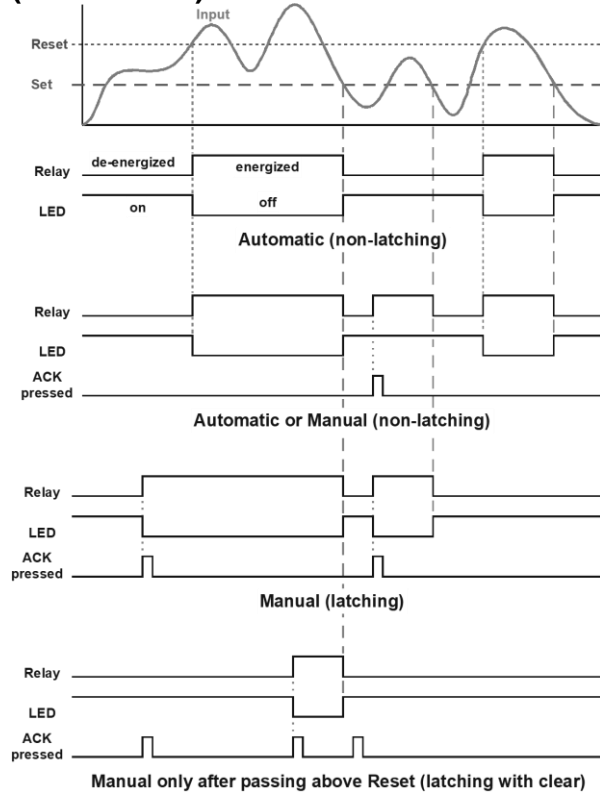

*Note: Relay coil is energized in non-alarm condition. In case of power failure, relay will go to alarm state.*

### Pump Alternation Control Operation

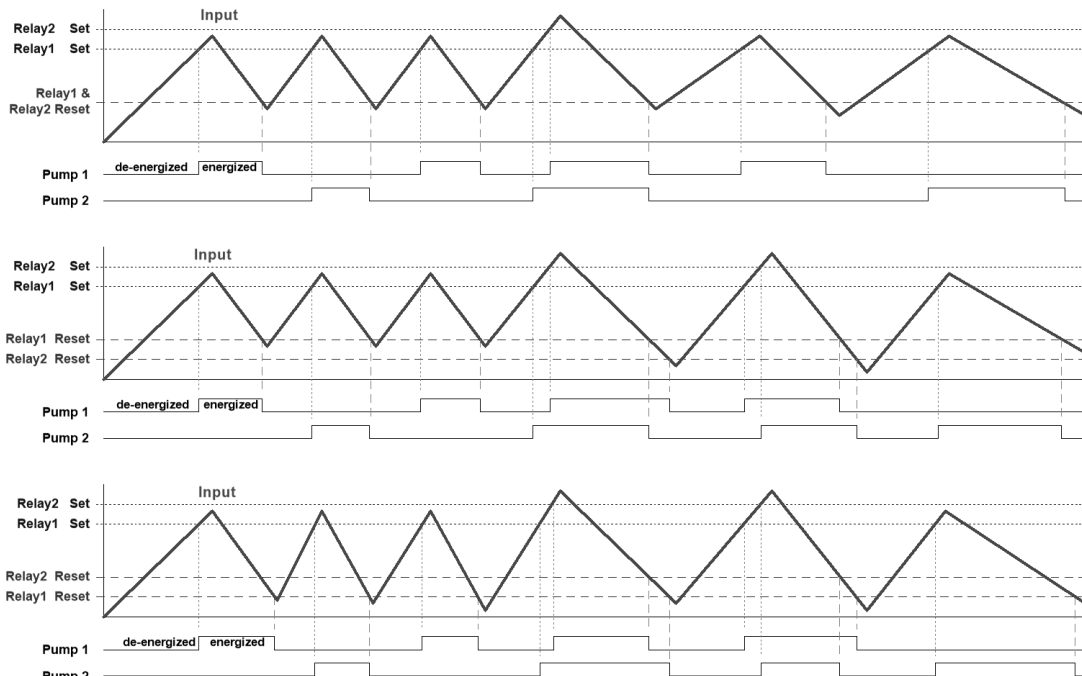

LEDs indicate the relay status

## Relay Sampling Operation

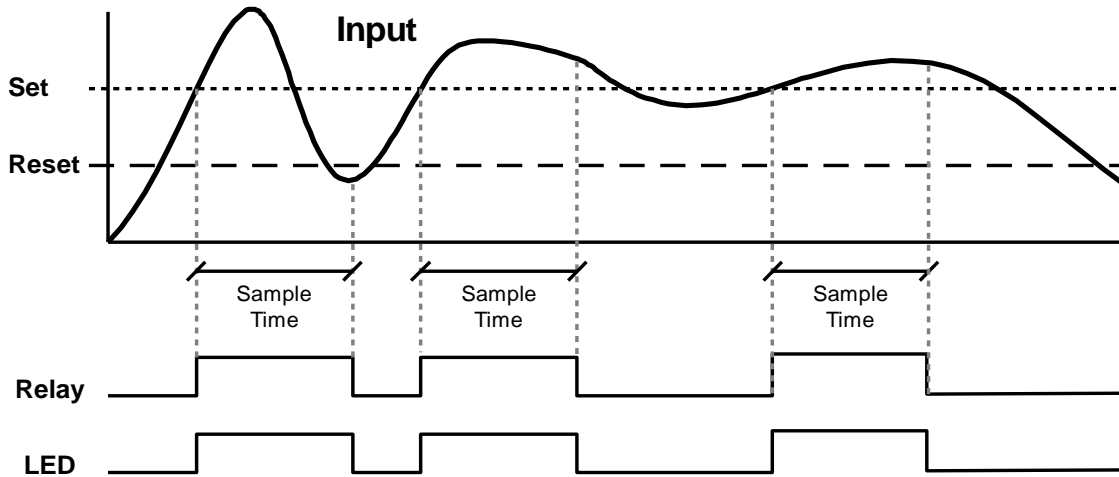

When the signal crosses the set point, the relay trips and the sample time starts. After the sample time has elapsed, the relay resets. The cycle repeats every time the set point is crossed, going up for high alarms and going down for low alarms.

The sample time can be programmed between 0.1 and 5999.9 seconds.

## Relay Operation After Communications Break

When a Master scanner fails to receive a reply from the slave it is called a Communications Break. The relays can be programmed to react to this event by going On, Off, or No Action. After communication is restored the relays are turned off or on, based on their operating mode and their set and reset points, without regard to their prior state. This is similar to the auto initialization on power up. Below is a diagram showing three examples.

The same is true for a scanner set up to operate in Snooper mode.

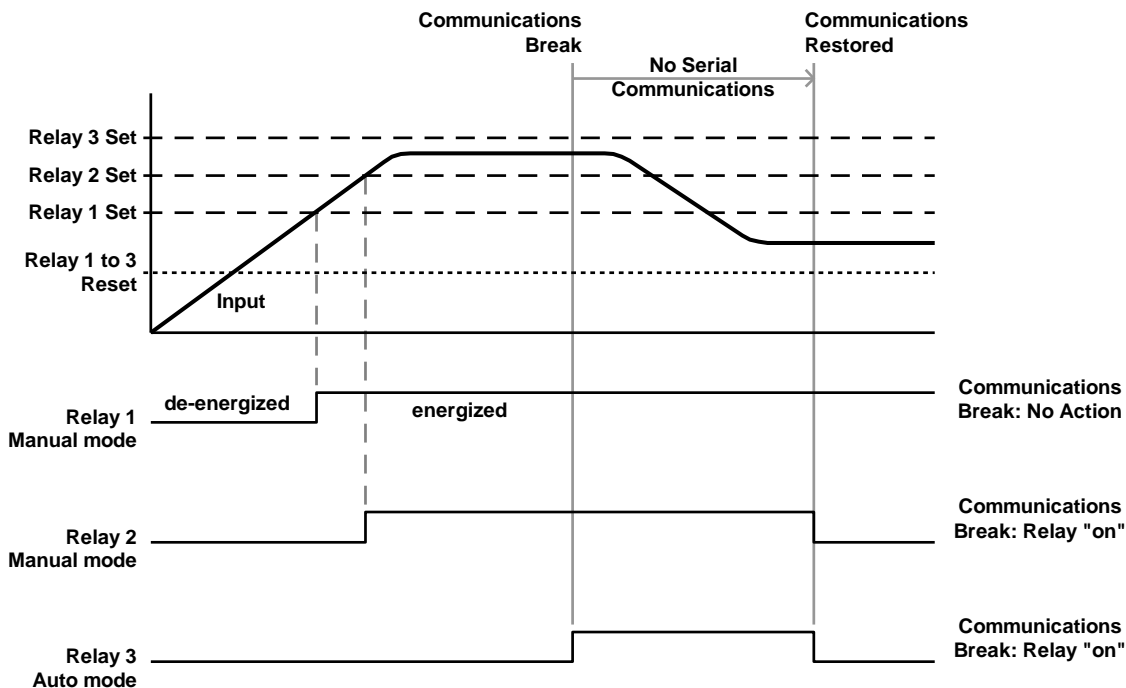

### Time Delay Operation

The following graphs show the operation of the time delay function.

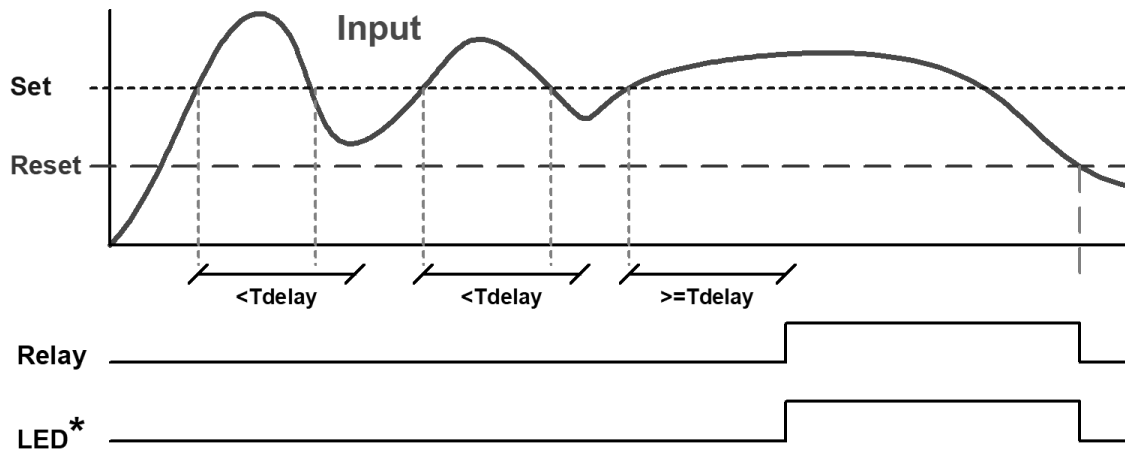

**On Time Delay**

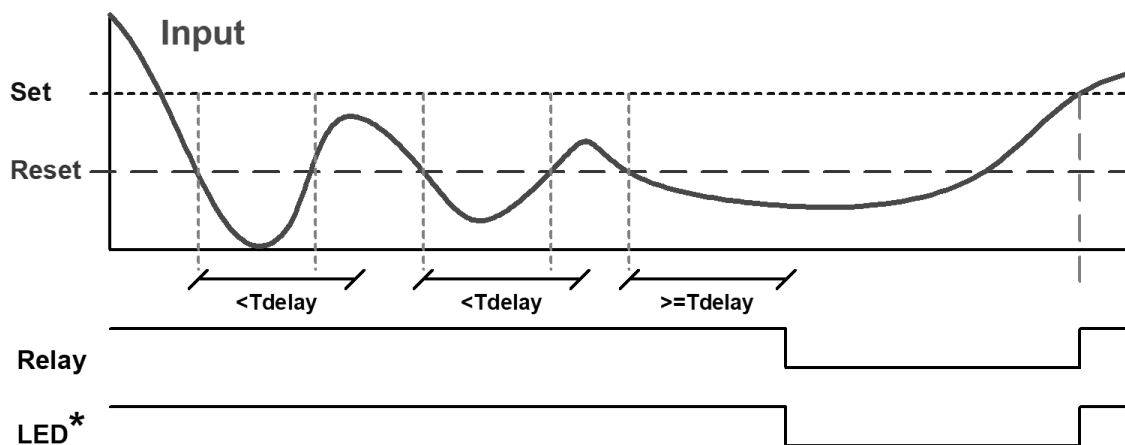

**Off Time Delay**

When the signal crosses the set point, the *On* time delay timer starts and the relay trips when the time delay has elapsed. If the signal drops below the set point (high alarm) before the time delay has elapsed, the *On* time delay timer resets and the relay does not change state. The same principle applies to the *Off* time delay.

*Note: If "Automatic or Manual (R-nr Rn)" reset mode is selected, the LED follows the reset point and not the relay state when the relay is acknowledged.*

## Relay Operation Details

### Overview

The relay capabilities of the scanner expand its usefulness beyond simple indication to provide users with alarm and control functions. These capabilities include front panel alarm status LEDs, as well as either 2 or 4 optional internal relays, and/or 4 external relays via expansion modules. Typical applications include high or low temperature, level, pressure or flow alarms, control applications such as simple on/off pump control, and pump alternation control for up to 8 pumps. There are four basic ways the relays can be used:

1. High or Low Alarms with Latching or Non-Latching Relays
2. Simple On/Off Control with 100% Adjustable Deadband
3. Sampling (Based on Time)
4. Pump Alternation Control for up to 8 Pumps

### Relays Auto Initialization

When power is applied to the scanner, the front panel LEDs and alarm relays will reflect the state of the input to the scanner after the first response from the slave device. The following table indicates how the alarm LEDs and relays will react on power-up based on the set and reset points:

Alarm #	HI or LO Alarm	Set Point	Reset Point	Power-Up Reading	Relay & LED
1	HI	1000	500	499	Off
2	LO	700	900	499	On
3	LO	250	400	499	Off
4	HI	450	200	499	On

### Fail-Safe Operation (FR & SF)

The following table indicates how the relays behave based on the fail-safe selection for each relay:

Fail-Safe Selection	Non-Alarm State		Alarm State		Power Failure
	NO	NC	NO	NC	
Off	Open	Closed	Closed	Open	Relays go to non-alarm state
On	Closed	Open	Open	Closed	Relays go to alarm state

*Note: NO = Normally Open, NC = Normally Closed. This refers to the condition of the relay contacts when the power to the scanner is off.*

### Front Panel LEDs

The LEDs on the front panel provide status indication for the following:

LED	Status
1	Alarm 1
2	Alarm 2
3	Alarm 3
4	Alarm 4

LED	Status
5	Alarm 5
6	Alarm 6
7	Alarm 7
8	Alarm 8

The scanner is supplied with four alarm points that include front panel LEDs to indicate alarm conditions. This standard feature is particularly useful for alarm applications that require visual-only indication. The LEDs are controlled by the set and reset points programmed by the user. When the display reaches a set point for a high or low alarm, the corresponding alarm LED will turn on. When the display returns to the reset point the LED will go off. The front panel LEDs respond differently for latching and non-latching relays.

For non-latching relays, the LED is always off during normal condition and always on during alarm condition, regardless of the state of the relay (e.g. Relay acknowledged after alarm condition).

For latching relays, the alarm LEDs reflect the status of the relays, regardless of the alarm condition. The following tables illustrate how the alarm LEDs function in relation to the relays and the acknowledge button (Default: F3 key assigned to ACK):

### Latching and Non-Latching Relay Operation

The relays can be set up for latching (manual reset) or non-latching (automatic reset) operation.

The On and Off terminology does not refer to the status of the relay's coil, which depends on the fail-safe mode selected.

Relay terminology for following tables	
Terminology	Relay Condition
On	Alarm (Tripped)
Off	Normal (Reset)
Ack	Acknowledged



**Warning!** *In latching relay mode, latched relays will reset (unlatch) when power is cycled.*

### Non-Latching Relay (RUTO)

In this application, the scanner is set up for automatic reset (non-latching relay). Acknowledging the alarm while it is still present has no effect on either the LED or the relay. When the alarm finally goes away, the relay automatically resets and the LED also goes off.

Automatic reset only		
Condition	LED	Relay
Normal	Off	Off
Alarm	On	On
Ack (No effect)	On	On
Normal	Off	Off

### Non-Latching Relay (R-nr Rn)

In this application, the scanner is set up for automatic and manual reset at any time (non-latching relay). The LED and the relay automatically reset when the scanner returns to the normal condition.

The next time an alarm occurs, the operator acknowledges the alarm manually while the alarm condition still exists. This causes the relay to reset, but the LED stays on until the scanner returns to the normal condition.

Automatic + manual reset at any time		
Condition	LED	Relay
Normal	Off	Off
Alarm	On	On
Normal	Off	Off
Next Alarm	On	On
Ack	On	Off
Normal	Off	Off

### Latching Relay (LRtCH)

In this application, the scanner is set up for manual reset at any time. Acknowledging the alarm even if the alarm condition is still present resets the relay and turns off the LED.

Manual reset any time		
Condition	LED	Relay
Normal	Off	Off
Alarm	On	On
Ack	Off	Off

### Latching Relay (LRt-CLR)

In this application, the scanner is set up for manual reset only after the signal passes the reset point (alarm condition has cleared). Acknowledging the alarm while it is still present has no effect on either the LED or the relay. When the alarm is acknowledged after it returns to the normal state, the LED and the relay go off. Notice that the LED remains on, even after the scanner returns to the normal condition. This is because, for latching relays, the alarm LED reflects the status of the relay, regardless of the alarm condition.

Manual reset only after alarm condition has cleared		
Condition	LED	Relay
Normal	Off	Off
Alarm	On	On
Ack (No effect)	On	On
Normal	On	On
Ack	Off	Off

### Acknowledging Relays

There are two ways to acknowledge relays programmed for manual reset:

1. Via the programmable F4 digital input assigned to ACK (Default) and connected to a normally open pushbutton wired across F4 and COM.
2. Remotely via a normally open pushbutton wired across one of the digital inputs and the +5 V terminals on the digital I/O modules, which is triggered with a contact closure to COM, or with an active low signal (see page8).

When the ACK button or the assigned digital input is closed, all relays programmed for manual reset are acknowledged.

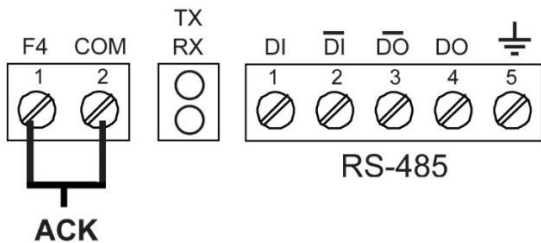

Figure 14. Acknowledge Relays with F4 Function Key

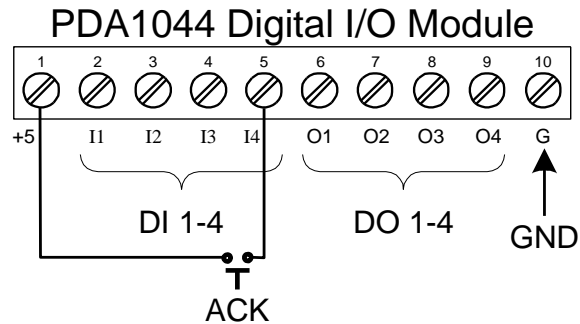

Figure 15. Acknowledge Relays with Digital Input

### Pump Alternation Control Applications (RLtErn)

For pump control applications where two or more similar pumps are used to control the level of a tank or a well, it is desirable to have all the pumps operate alternately. This prevents excessive wear and overheating of one pump over the lack of use of the other pumps.

Up to 8 relays can be set up to alternate every time an on/off pump cycle is completed. The set points and reset points can be programmed, so that the first pump on is the first pump off.

#### Application #1: Pump Alternation Using Relays 1 & 2

1. Relays 1 and 2 are set up for pump alternation.
2. Relays 3 and 4 are set up for low and high alarm indication.

Set and Reset Point Programming with Pump Alternation			
Relay	Set Point	Reset Point	Function
1	30.000	10.000	Controls pump 1 & 2
2	35.000	5.000	Sets dual pump trigger
3	4.000	9.000	Controls low alarm
4	40.000	29.000	Controls high alarm

#### Pump Alternation Operation

1. Pump #1 turns on when the level reaches 30.000, when the level drops below 10.000 pump #1 turns off.
2. The next time the level reaches 30.000, pump #2 turns on, when the level drops below 10.000, pump #2 turns off.
3. If the level doesn't reach 35.000 pump #1 and pump #2 will be operating alternately.
4. If pump #1 cannot keep the level below 35.000 pump #2 will turn on at 35.000, then as the level drops to 10.000 pump #1 turns off, pump #2 is still running and shuts off below 5.000.
5. Notice that with the set and reset points of pump #2 outside the range of pump #1, the first pump on is the first pump to go off. This is true for up to 8 alternating pumps, if set up accordingly.
6. Relay #3 will go into alarm if the level drops below 4.000 and relay #4 will go into alarm if the level exceeds 40.000.
7. Adding the 4 external relays expansion module allows using the 4 SPDT internal relays for pump alternation and the 4 SPST external relays for high, high-high, low, and low-low alarm indication.

### Setting Up the Interlock Relay (Force On) Feature

Relays 1-4 can be set up as interlock relays. To set up the relays for the interlock feature:

1. Access the *Setup – Relay – Action* menu and set the action to off.

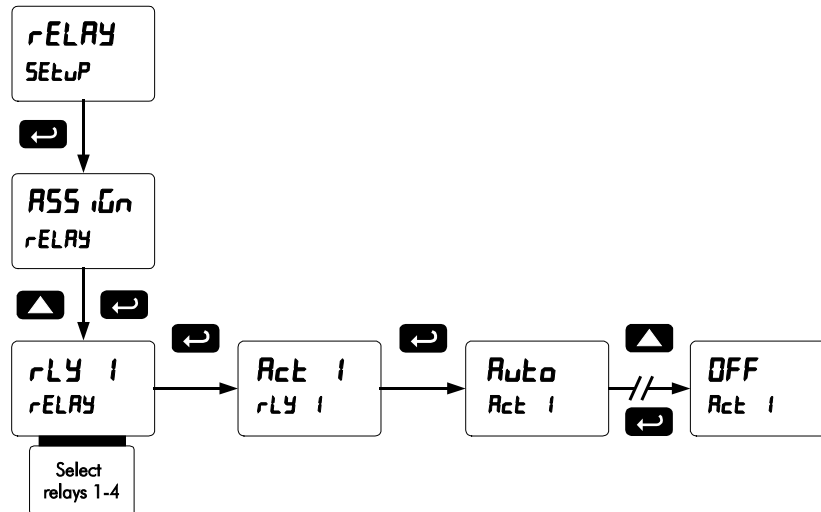

2. In the *Advanced features – User* menu, program any of the digital inputs to *Force On* any of the internal relays (1-4). The *Advanced Features Menu* can be found on page 51.

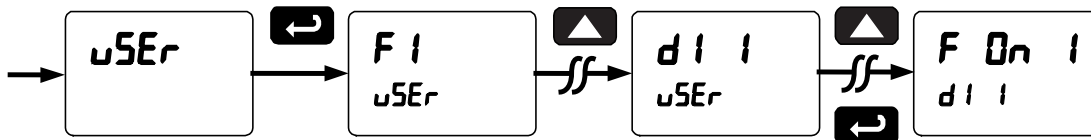

3. Connect a switch or dry contact between the +5V terminal and the corresponding digital input (DI-1 to DI-4) terminal.

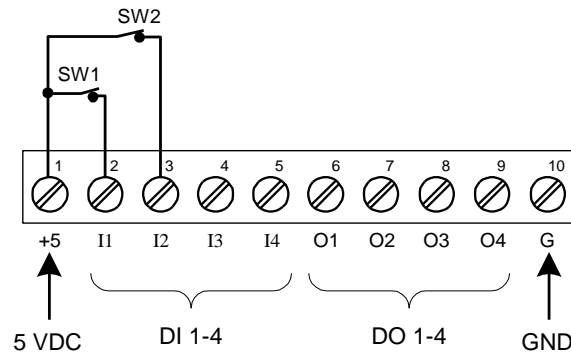

### Interlock Relay Operation Example

Relays 1 & 2 are configured to energize (their front panel LEDs are off) when SW1 & SW2 switches (above) are closed. If the contacts to these digital inputs are opened, the corresponding front panel LEDs flash, indicating this condition. The processes being controlled by the interlock relay will stop, and will re-start only after the interlock relay is re-activated by the digital inputs (switches).

*Note: If multiple digital inputs are assigned to the same relay, then the corresponding logic is (AND) – i.e. both switches must be closed to trip the relay.*



## Scaling the 4-20 mA Analog Output (Rout)

The 4-20 mA analog outputs can be scaled to provide a 4-20 mA signal for any display range selected. The Analog Outputs can be mapped to PVs or Math Channels. To select the channel and source assignments the analog outputs are assigned to, see *Analog Output Source Programming* on page 64.

No equipment is needed to scale the analog outputs; simply program the display values to the corresponding mA output signal.

The *Analog Output* menu is used to program the 4-20 mA outputs based on display values.

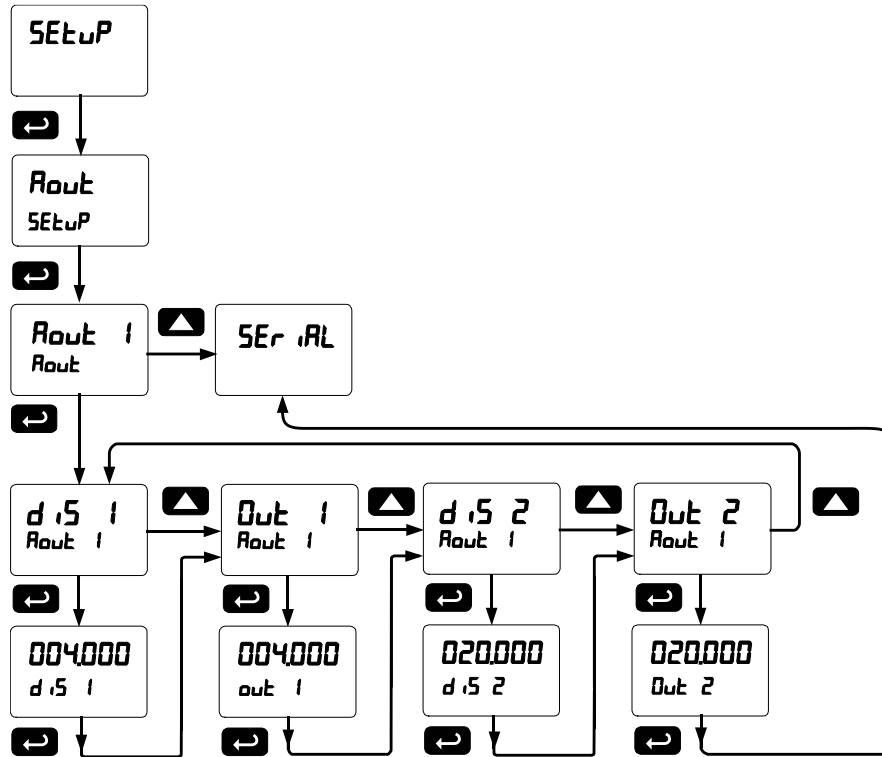

There are three analog outputs available. These only display when they are enabled. See graphic below.

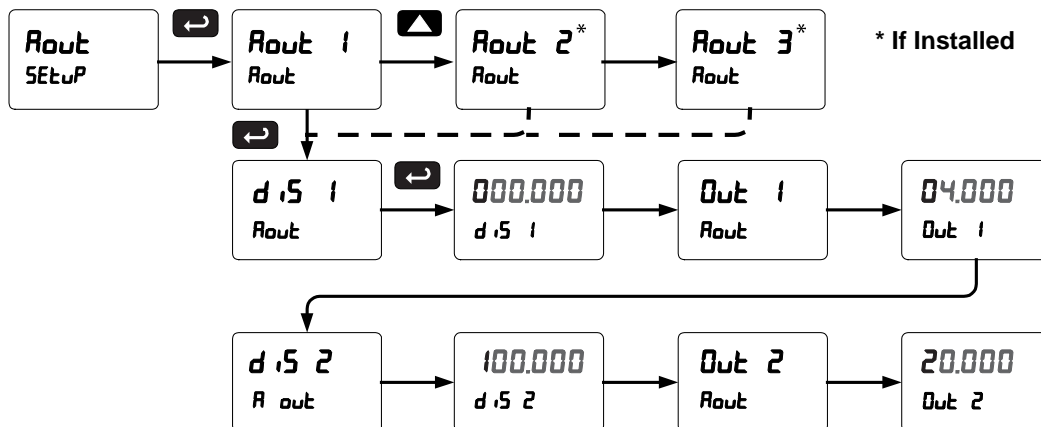

*Notes: Changes to the settings are saved to memory only after pressing ENTER. Changes made to settings prior to pressing ENTER are not saved. Once ENTER is pressed, the display moves to the next menu.*

## Setting Up the Password (PASS)

The *Password* menu is used for programming three levels of security to prevent unauthorized changes to the programmed parameter settings.

Pass 1: Allows use of function keys and digital inputs  
 Pass 2: Allows use of function keys, digital inputs and editing set/reset points  
 Pass 3: Restricts all programming, function keys, and digital inputs.

### Protecting or Locking the Scanner

Enter the *Password* menu and program a six-digit password.

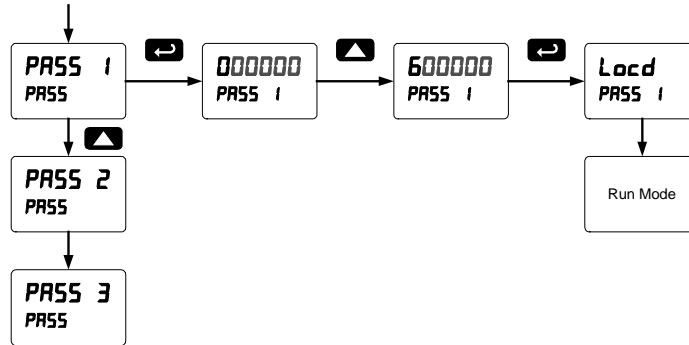

### Making Changes to a Password Protected Scanner

If the scanner is password protected, the scanner will display the message **Locd** (*Locked*) when the Menu button is pressed. Press the Enter button while the message is being displayed and enter the correct password to gain access to the menu. After exiting the programming mode, the scanner returns to its password protected condition.

### Disabling Password Protection

To disable the password protection, access the *Password* menu and enter the correct password twice, as shown below. The scanner is now unprotected until a new password is entered.

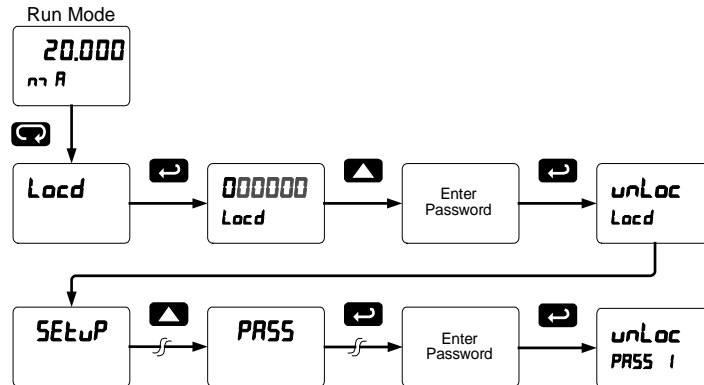

If the correct six-digit password is entered, the scanner displays the message **unLoc** (*Unlocked*) and the protection is disabled until a new password is programmed.

If the password entered is incorrect, the scanner displays the message **Locd** (*Locked*) for about two seconds, and then it returns to Run Mode. To try again, press Enter while the *Locked* message is displayed.

**Did you forget the password?**  
 The password may be disabled by entering a master password once. If you are authorized to make changes, enter the master password 508655 to unlock the scanner.

## Advanced Features Menu

To simplify the setup process, functions not needed for most applications are located in the *Advanced Features* menu:

1. *Scan Mode: Auto or manual; Go on alarm or stop on alarm*
2. *Control relays and analog output*
3. *Noise Filter*
4. *Noise Filter Bypass*
5. *Rounding Feature*
6. *Select Math, Linearization function, Cutoff*
7. *User Programming for function keys and digital I/O*
8. *Copy Feature*
9. *System Information*

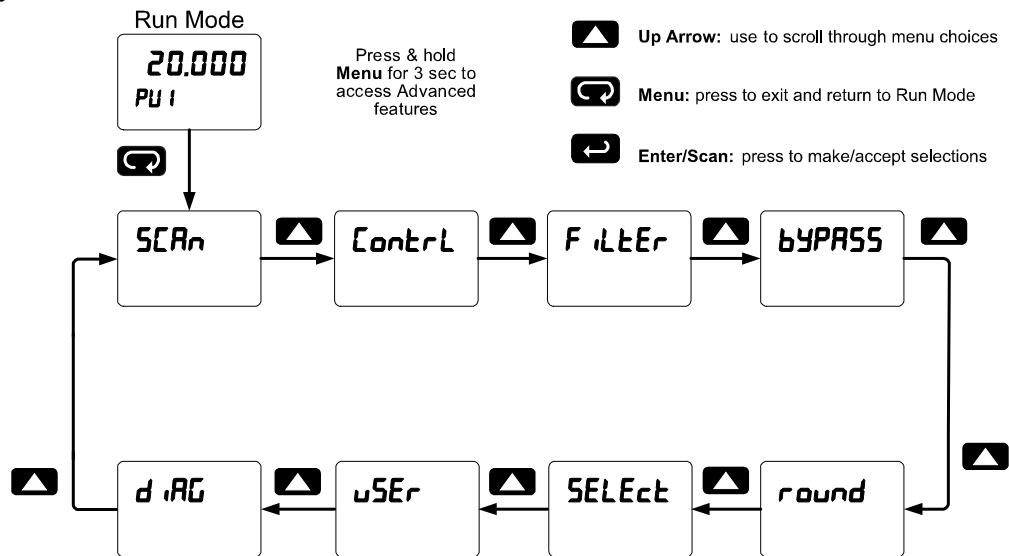

### Advanced Menu Navigation Tips:

- Press and hold the **Menu** button for three seconds to access the Advanced Features Menu.
- Press the **Up** arrow button to scroll through the Advanced Features Menu.
- Press **Menu** at any time, to exit and return to Run mode.
- Changes made to settings prior to pressing **Enter/Scan** are not saved.
- Changes to the settings are saved to memory only after pressing **Enter/Scan**.
- The display automatically moves to the next menu every time a setting is accepted by pressing **Enter/Scan**.

### Advanced Features Menu & Display Messages

Display	Parameter	Action/Setting	Display	Parameter	Action/Setting
5CRn	Scan	Enter Scan menu	no PLS	Number of Points	Enter Number of Linearization Points
na de	Scan Mode	Select Auto or Manual Scan Mode	SCALE	Scale	Scale Number of Linearization Points
Ruao	Automatic	Select Automatic Scan Mode	inp 1	Input 1	Program input 1 value
E rno E	Scan Time	Select Scanning Time	d 5 1	Display 1	Program display 1 value
na Rn	Manual	Select Manual Scan Mode	inp 2	Input 2	Program input 2 value (up to 32 points for PV1 & PV2)
RLRna	Alarm	Select Go or Stop Alarm	d 5 2	Display 2	Program display 2 value (up to 32 points for PV1 & PV2)
no	Go	Select Alarm Go	SqurRE	Square Root	Enter Square Root menu
StoP	Stop	Select Alarm Stop	ProG E	Programmable Exponent	Enter Programmable Exponent menu
Control	Control	Enter Control menu for relays and analog output 1	15000	Programmable Exponent Value	Enter the Programmable Exponent Value
Ruao	Automatic	Select Automatic Control of Outputs and Relays	rht	Round Horizontal Tank	Enter Round Horizontal Tank menu
na Rn	Manual	Select Manual Control of Outputs and Relays	inch	Inch	Enter to calculate tank values in Inches
Rout 1	Analog Output 1	Select Analog Output 1 for manual control	cm	Centimeters	Enter to calculate tank values in Centimeters
RLY 1	Relay 1	Select Relay 1-8 for manual control	d Rn r	Diameter	Enter tank diameter
on	On	Select On for Relay 1-8	LEnGth	Length	Enter tank length
off	Off	Select Off for Relay 1-8	na Rth	Math	Enter Math menu
F ILtEr	Filter	Enter Filter menu	Ch C 1*	Channel C1	*Enter Math Channel C1-C4 menu
PV 1	PV 1 Filter	Program Filter Value for PV 1	OPERtN	Operation	Enter Math Operation menu
PV 2	PV 2 Filter	Program Filter Value for PV 2	Const	Constant	Enter Math Constant menu
bYPASS	Filter Bypass	Enter Filter Bypass menu	AddEr	Adder	Enter Adder Value
PV 1	PV 1 Filter Bypass	Program Filter Bypass Value for PV 1	FRctR	Factor	Enter Factor Value
PV 2	PV 2 Filter Bypass	Program Filter Bypass Value for PV 2	SuM	Sum	Math Function Sum
round	Rounding Feature	Enter Rounding Feature menu	d iF	Difference	Math Function Difference
1*	1 Rounding Value	Program Rounding Value for PV *(User-selectable & rounds to the nearest 1, 2, 5, 10, 20, 50, 100)	d iFABS	Absolute Difference	Math Function Absolute Difference
SELEct	Select	Enter Select menu	RuG	Average	Math Function Average
FunctN	Function	Enter data Linearization Function menu	na SL 1	Multiply	Math Function Multiply
PV 1*	PV 1 Function	*Enter Linearization Function menu for all enabled PVs	d u dE	Divide	Math Function Divide
Ch C 1*	Ch C1 Function	*Enter Linearization Function menu for all enabled math channels	H -PV	Max	Math Function Maximum of all selected PVs
LInER	Linear	Enter Linear menu	Lo-PV	Min	Math Function Minimum of all selected PVs
			drRu	Draw	Math Function Draw
			WtRd	Weighted Average	Math Function Weighted Average
			rRt	Ratio	Math Function Ratio

Display	Parameter	Action/Setting
ConcEn	Concentration	Math Function Concentration
Math2	Math2	Resultant Math Channel Math operation applied to other math channels (e.g. C3 = C1/C2)
Sum	Sum	Math2 Function Sum
dif	Difference	Math2 Function Difference
difAbs	Absolute Difference	Math2 Function Absolute Difference
Avg	Average	Math2 Function Average
Multiply	Multiply	Math2 Function Multiply
Divide	Divide	Math2 Function Divide
Cutoff	Cutoff	Enter Low Flow Cutoff menu
PV 1	PV 1 Cutoff	Program Cutoff Value for PV 1
PV 2	PV 2 Cutoff	Program Cutoff Value for PV 2
RoutePr	Analog Output Program	Enter Analog Output Programmable parameters menu
Route 1*	Analog Output 1-3	*Analog Output 1-3 (If Installed)
Source	Analog Output Data Source	Enter Analog Output Data Source menu
PV 1*	Source PV	*Select PV for Analog Output Data Source
Ch 1*	Source Math Channel	*Select C1-4 for Analog Output Data Source
Set 1*	Set Point 1-8	*Select Set Points 1-8
brERH	Communications Break	Enter the Analog Output value when Communications Break is detected
Ignore	Ignore Break	Ignore Break
Force	Force Break	Force Break
Calib	Calibration	Enter the Analog Output Calibration menu
Max	Maximum	Select Maximum value for all Analog Outputs
Min	Minimum	Select Minimum value for all Analog Outputs
Over	Overrange	Enter the Analog Output value for an Overrange condition
Under	Underrange	Enter the Analog Output value for an Underrange condition
User	User	Enter the User menu for assigning function keys and digital I/O
F 1*	F1-4	*F1-F4 Function Keys

Display	Parameter	Action/Setting
PREV	Previous	Previous PV
NEXT	Next	Next PV
SCAN	Scan	Scan or pause scan
ACK	Acknowledge	Acknowledge relays
RESET	Reset	Enter Reset menu
Reset Max	Reset Max	Reset Maximum
Reset Min	Reset Min	Reset Minimum
Reset HL	Reset Max-Min	Reset Maximum & Minimum
RELAY	Relay	Relay menu
Set 1*	Set Points 1-8	Set Points 1-8
Relay D	Relay Disable	Relay Disable (all relays)
Relay E	Relay Enable	Relay Enable (all relays)
Output Hold	Output Hold	Output Hold (all relays)
Display Hold	Display Hold	Display Hold (while held low)
Disable	Disable	Disable
Control	Control	Control menu
DI 1*	DI 1-8	*Digital Inputs 1-8
Menu	Menu	Menu
Right	Right	Right
Up	Up	Up
Enter	Enter	Enter
Force On Relay 1	Force On Relay 1	*Force On Relay 1-4
DO 1*	DO 1-8	*Digital Outputs 1-8
Alarm 1*	Alarm 1-8	*Alarm 1-8
ACK	Acknowledge	Acknowledge
RESET	Reset	Enter Reset menu
Reset Max	Reset Max	Reset Maximum
Reset Min	Reset Min	Reset Minimum
Reset HL	Reset Max-Min	Reset Maximum & Minimum
Disable	Disable	Disable
Diagnostic	Diagnostic	Enter Diagnostics menu
RESET	Reset	Reset to Factory Defaults
LED Test	LED Test	LEDs cycle through all digits, decimal points, and indicators
Info	Info	Displays Scanner information
Software	Software	Displays Software information
Version	Software Version	Displays Software Version information

### Scan Function (SCAn)

The *Scan* menu is used to program the PV scan mode and the scanner's behavior on alarm condition. The operator is able to scan automatically based on a time parameter, or scan manually with front panel keys or digital inputs. The operator is also able to set the scanner to stop on alarm or continue scanning on alarm. To resume scanning the operator must press the Next or Previous button. Please follow the menu below for details. In the Stop on Alarm mode, the scanner will go to the alarmed PV and remain there until the operator manually advances to the next PV or returns to the previous PV. If a new alarm is detected the process is repeated. The scanner ignores old alarms.

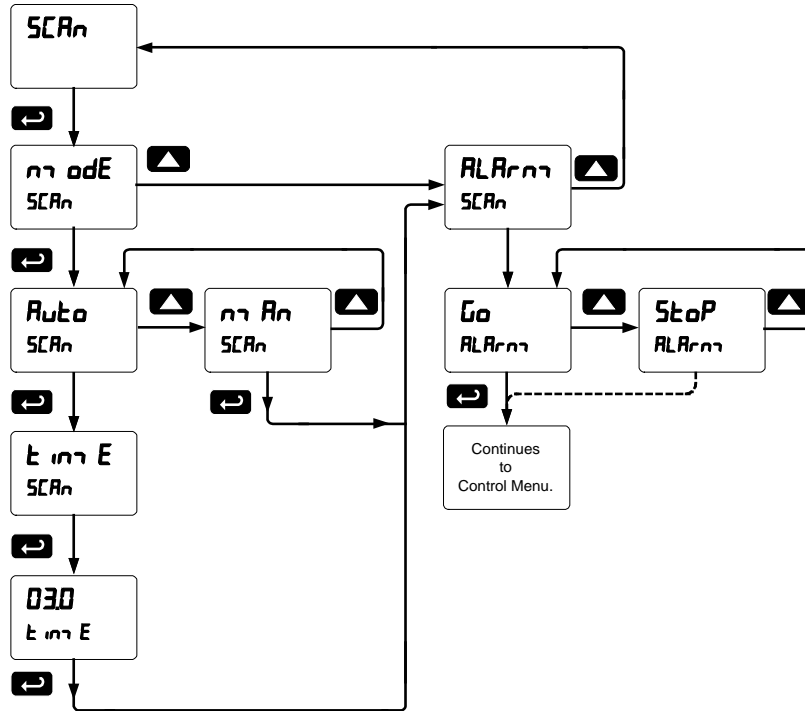

### Control Menu (ContrL)

The *Control* menu is used to control the 4-20 mA analog output and the relays manually, ignoring the input. Each relay and analog output can be programmed independently for manual control. Selecting automatic control sets all relays and analog output for automatic operation.

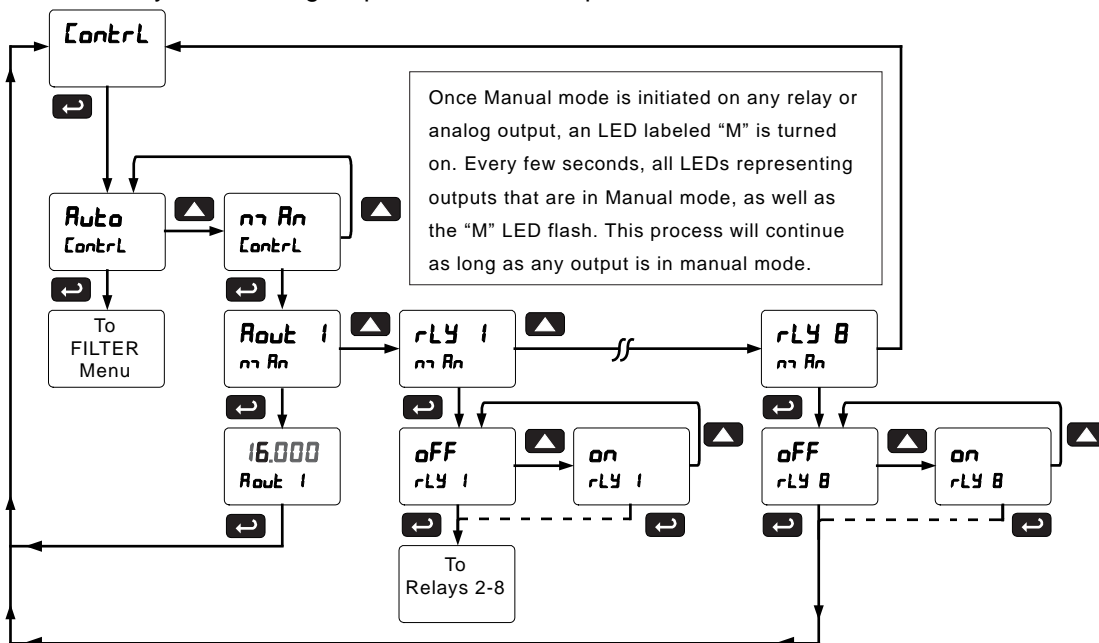

### Noise Filter (F ILtEr)

Most applications do not require changing this parameter. It is intended to help attain a steady display with unsteady (noisy) input data. The field selectable noise filter averages any minor or quick changes in the input data and displays the reading with greater stability. Increasing the filter value will help stabilize the display. However, this will reduce the display response to changes on the input data. The filter level may be set anywhere from 2 to 199. Setting the filter value to zero disables the filter function, and the bypass setting becomes irrelevant.

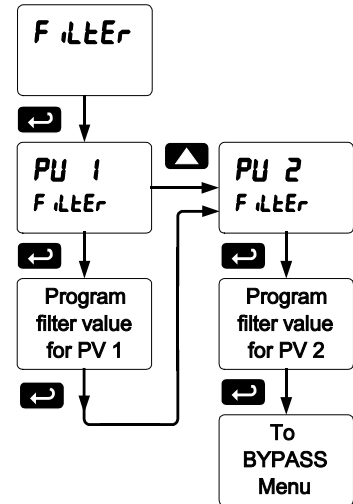

### Noise Filter Bypass (bYPASS)

The scanner can be programmed to filter small input changes, but allow larger input changes to be displayed immediately, by setting the bypass value accordingly. If the input signal goes beyond the bypass value, it will be displayed immediately with no averaging done on it. The noise filter bypass value may be set anywhere from 0.2 to 99.9. Increasing the bypass value may slow down the display response to changes on the input signal.

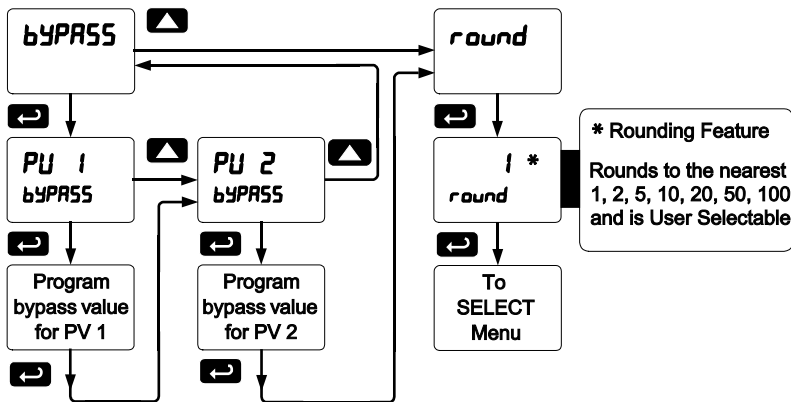

### Rounding Feature (round)

The rounding feature is used to give the user a steadier display with fluctuating signals. Rounding is used in addition to the filter function. Rounding causes the display to round to the nearest value according to the rounding criteria selected by the user. This setting affects the last three digits, regardless of decimal point position.

### Select Menu (SELEct)

The *Select* menu is used to select the input data linearization function (linear, square root, programmable exponent, or round horizontal tank), math functions, constants, low-flow cutoff, and analog output programming. Multi-point linearization is part of the linear function selection.

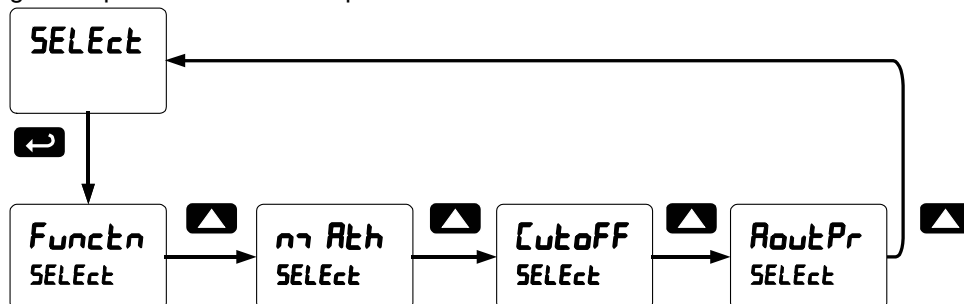

### Input Data Conditioning Function Menu (*Function*)

The *Function* menu is used to select the input-to-output transfer function applied to the input data: linear, square root, programmable exponent, or round horizontal tank volume calculation. Multi-point linearization (for PV1 and PV2) is part of the linear function selection. Scanners are set up at the factory for linear function with 2-point linearization. The linear function provides a display that is linear with respect to the input data (e.g. 0.000 = 0.000, 10.000 = 10.000, and then 5.000 = 5.000).

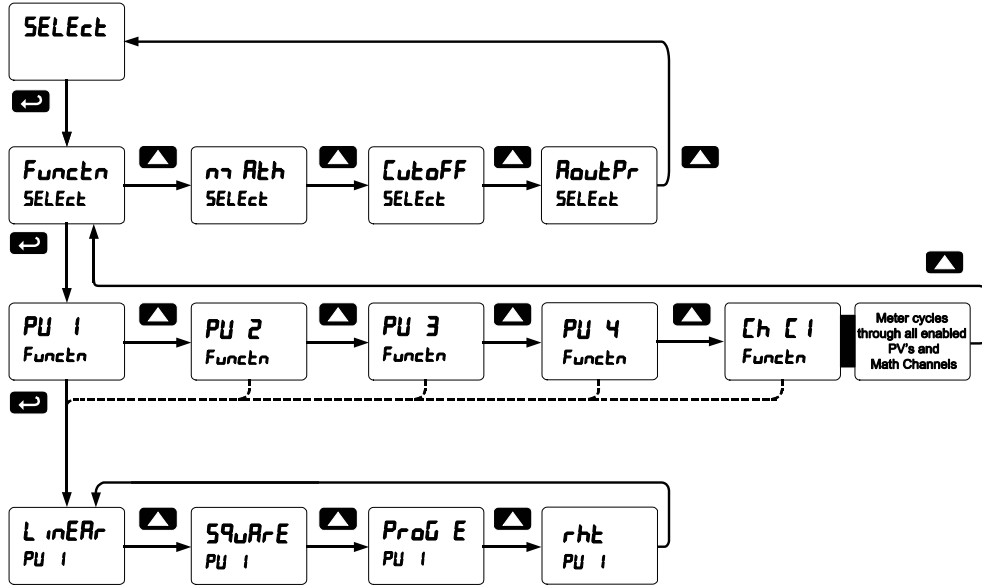

### Linear Function Menu (*L inERr*)

Scanners are set up at the factory for linear function with 2-point linearization. Up to 32 linearization points can be selected for PV1 and PV2 under the *Linear* function in the *Advanced Features* menu. The multi-point linearization can be used to linearize the display for non-linear signals such as those from level transmitters used to measure volume in odd-shaped tanks or to convert level to flow using weirs and flumes with complex exponents.

*Note: Multi-point Linearization applies to PV1 and PV2 only. All other PVs use two linearization points.*

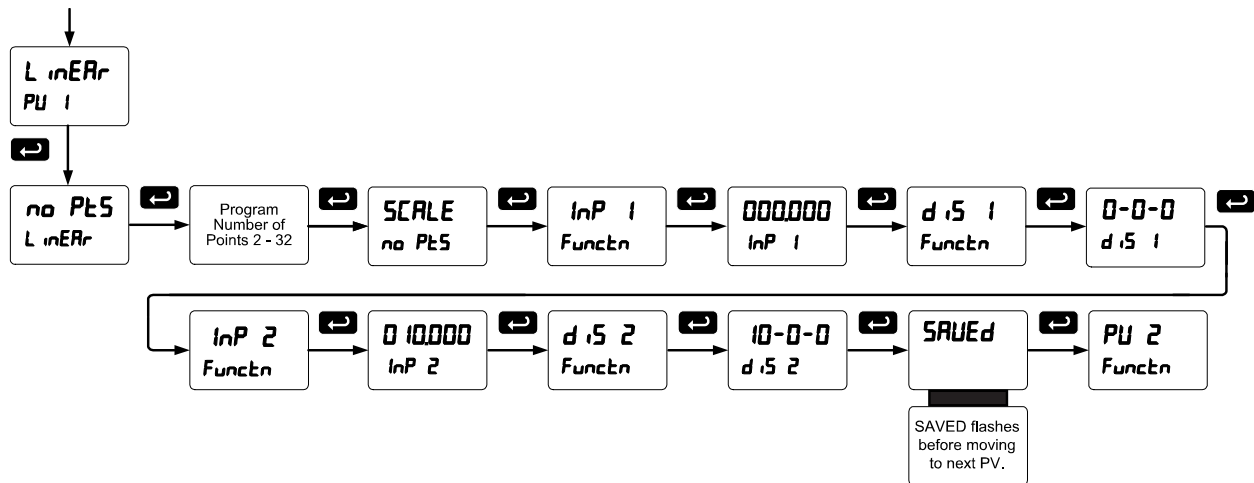



### Square Root Function Menu (SQURrE)

The square root function is used to calculate flow measured with a differential pressure transmitter. The flow rate is proportional to the square root of the differential pressure. Scale the scanner so that the low input signal (e.g. 4 mA) is equal to zero flow and the high input signal (e.g. 20 mA) is equal to the maximum flow.

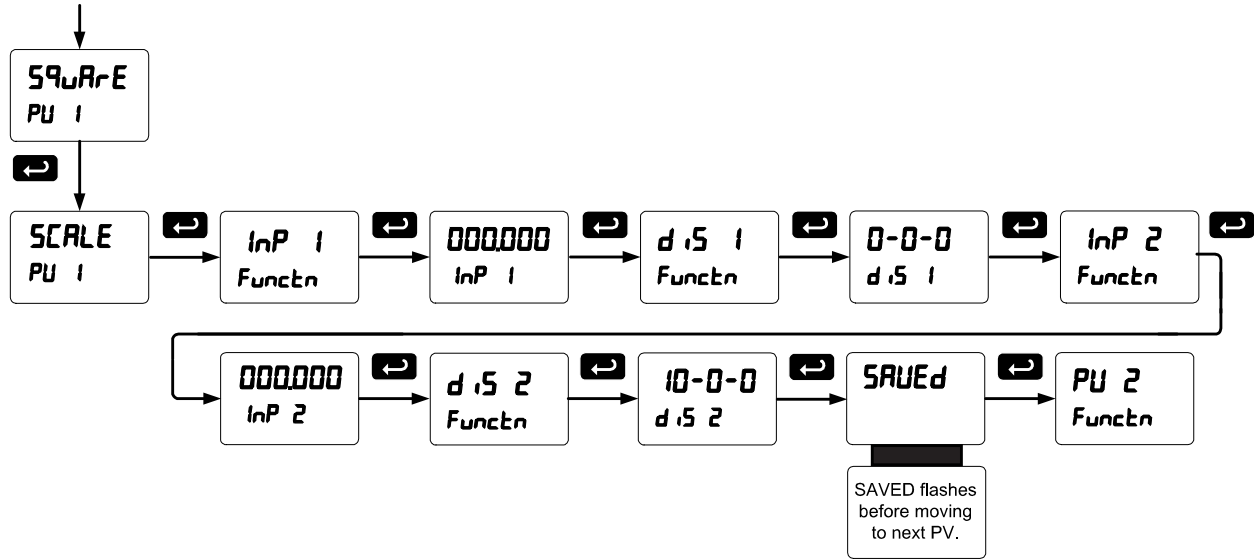

### Programmable Exponent Function Menu (ProG E)

The programmable exponent function is used to calculate open-channel flow measured with a level transmitter in weirs and flumes. The flow rate is proportional to the head height. Scale the scanner so that the low input signal (e.g. 4 mA) is equal to zero flow and the high input signal (e.g. 20 mA) is equal to the maximum flow. This method works well for all weirs and flumes that have a simple exponent in the flow calculation formula. For weirs and flumes with complex exponents it is necessary to use a strapping table and the 32-point linearization of the scanner.

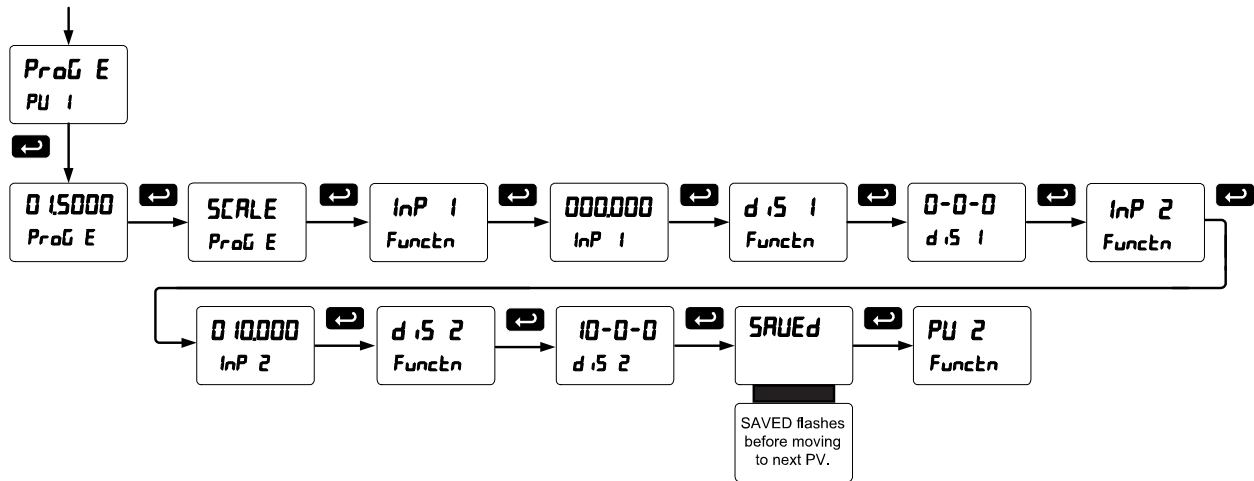

**Round Horizontal Tank Function Menu (rht)**

This function is used to calculate volume in a round horizontal tank with flat ends. The volume is calculated based on the diameter and length of the tank. The tank's dimensions can be entered in inches or centimeters; the scanner automatically calculates the volume in gallons or liters. After entering the dimensions, complete the scaling process with the display values calculated by the scanner. The scanner can be re-scaled to display the volume in any engineering unit without the need to re-enter the dimensions again.

**Changing the Volume from Gallons to Liters**

In the above graphic, entering the 48" for the diameter and 120" for the length of the round horizontal tank, the scanner automatically calculates that the volume of the tank is 940.02 gallons.

1. Convert gallons to liters  
1 US gallon = 3.7854 L  
940.02 gal = 3558.4 L
2. Go to the *Setup - PV - Decimal Point* menu and change the decimal point to 1 decimal.
3. Go to the *Setup - PV - Scale* menu and press Enter until **d 1.5 2** is shown on line 1.
4. Press Enter and change the display 2 value to 3558.4.
5. The scanner is now displaying the volume in liters.

*Note: The display can be scaled to display the volume in any engineering units.*

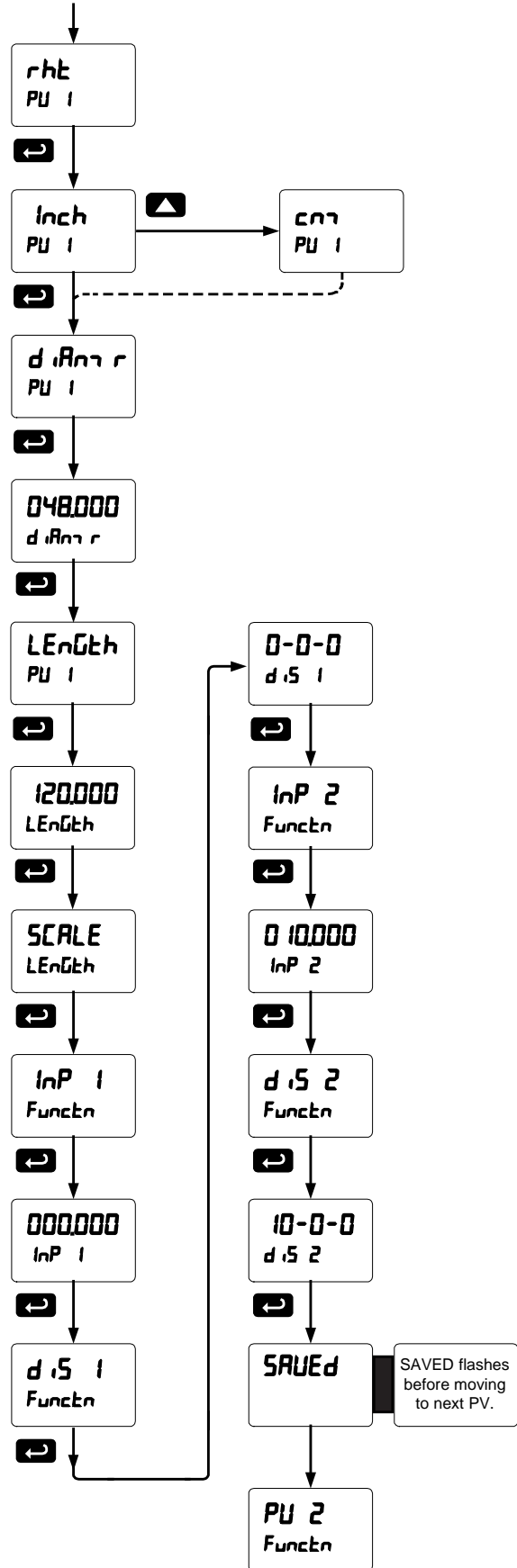

### Math Functions (הר אלה)

The *Math* menu is used to select the math function that will determine the channels C1-C4 value. These math functions are applied to PVs and other math channels. The results are displayed by selecting Display Channel C (ד לח ל) in the *Display* menu. Most math functions may be applied to all PVs: For example, it is possible to add up to 16 PVs and calculate the total volume of all the tanks in a field. The Math2 function allows for further calculations on the results of other math channels (e.g. C4 = C2/C1).

The following math functions are available:

Name	Math Operation (Examples) (P = Adder, F = Factor)	Setting
Addition	$(PV1+PV2+P)*F$	סחטט
Difference	$(PV1-PV2+P)*F$	ד ו F
Absolute difference	$((Abs(PV1- PV2)+P)*F$	ד ו F אבס
Average	$((PV1+PV2)/2)+P)*F$	אמג
Multiplication	$((PV1*PV2)+P)*F$	ו לטטר
Division	$((PV1/PV2)+P)*F$	ד ו ד E
Max PV	Max value of all selected PVs	ח ו - P
Min PV	Min value of all selected PVs	ל ו - P
Draw	$((PV1/PV2)-1)*F$	ד ר אטט
Weighted average	$((PV2-PV1)*F)+PV1$	ט אטט
Ratio	$(PV1/PV2)*F$	ר א ל ו
Concentration	$(PV1/(PV1+PV2))*F$	ל אכע
Math 2	Math on other math channels	הר אלה 2
Addition	$C3 = (C1+C2+P)*F$	סחטט
Difference	$C4 = (C1-C2+P)*F$	ד ו F
Absolute difference	$C3 = ((Abs(C1- C2)+P)*F$	ד ו F אבס
Average	$C4 = (((C1+C2)/2)+P)*F$	אמג
Multiplication	$C3 = ((C1*C2)+P)*F$	ו לטטר
Division	$C4 = ((C1/C2)+P)*F$	ד ו ד E

### Math Constants (לכנסת)

The *Math Constants* menu is used to set the constants used in the math channel. The math functions include the selected PVs, as well as the constants P (Adder) and the Factor F (Multiplier) as indicated in the above examples.

The *Adder* constant (P) may be set from -99.999 to 999.999.

The *Factor* constant (F) may be set from 0.001 to 999.999.

The above chart details the math functions that may be selected in the *Math Function* menu.

Math Function Menu (מח אלה)

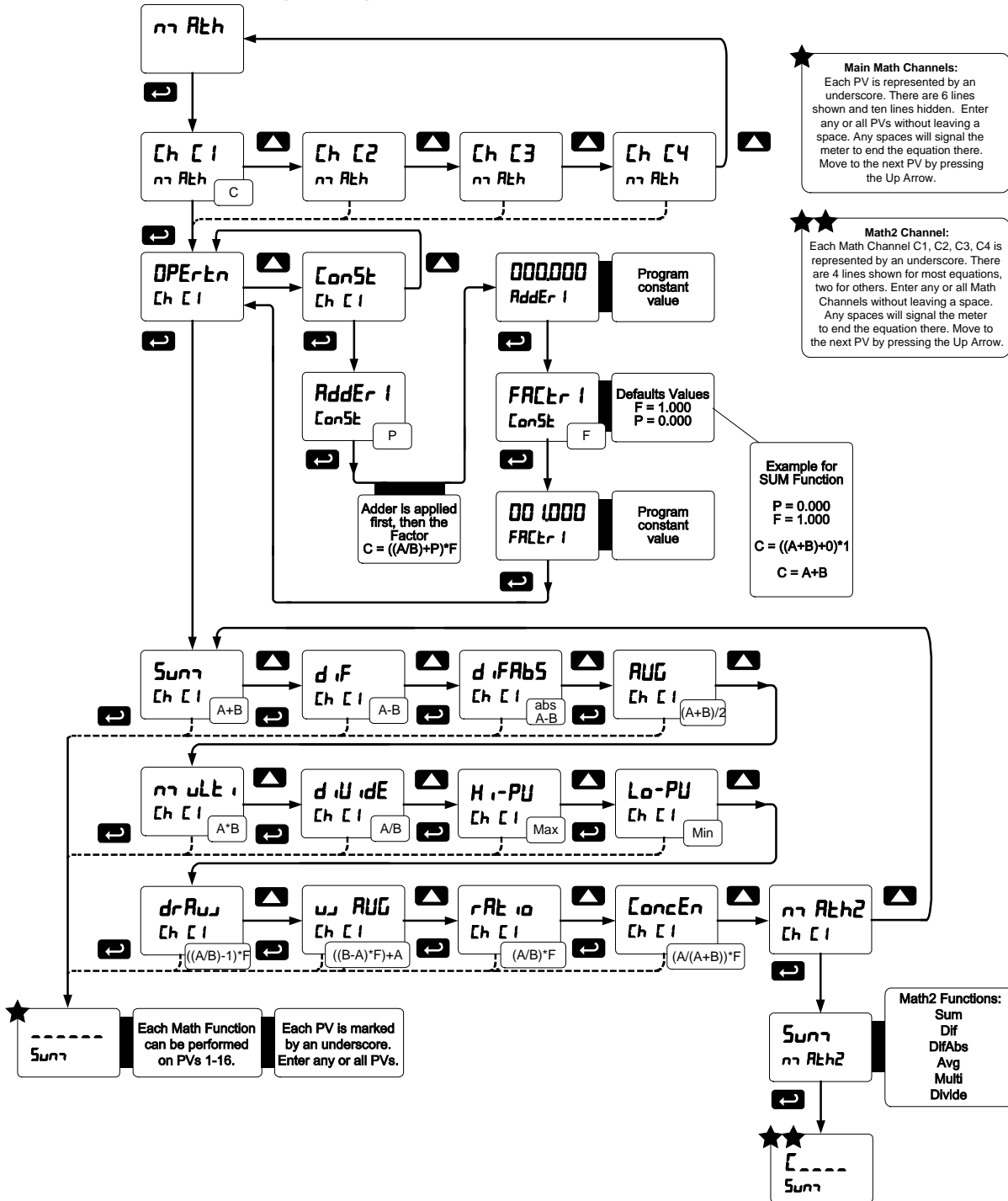

Notes:

1. In the above menu, "A" & "B" in equations can represent any PVs (PV1-PV16). See table above.
2. Each digit represents one PV in hexadecimal format, except PV16 (G).
3. PV1 – PV9 = 1 - 9, PV10 – PV16 = A – G
4. No PV selected = "underscore symbol"
5. Digit range: 1-G, then "\_"
6. If there is an empty digit, the scanner will end the equation at that point.
7. For Math2 Channel, "C" is fixed, indicating which Math Channels are being processed.
8. Please refer to the following graphics for details on various Math Functions:

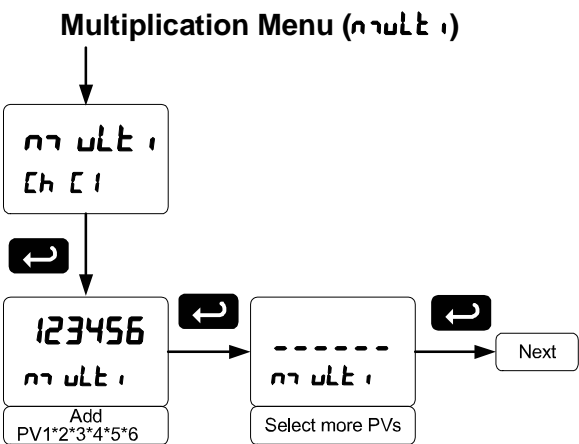
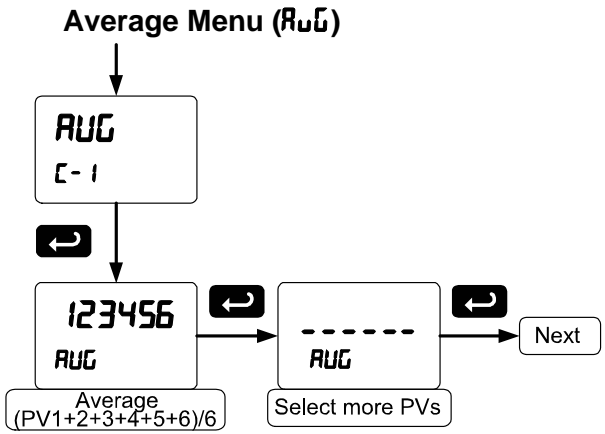
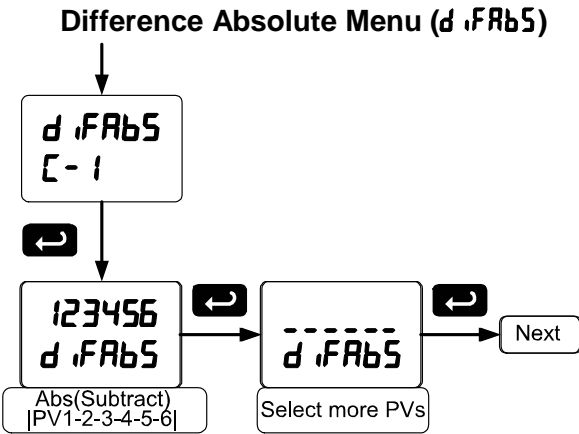
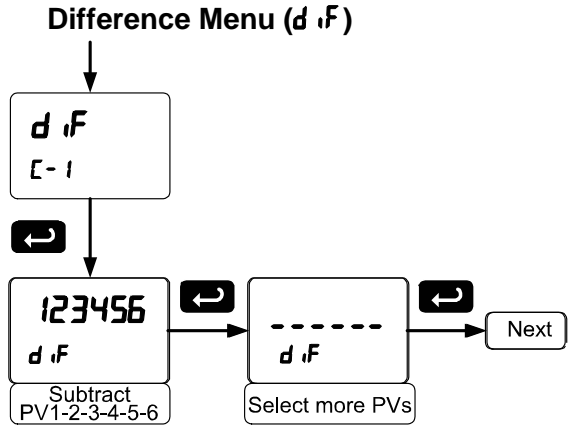
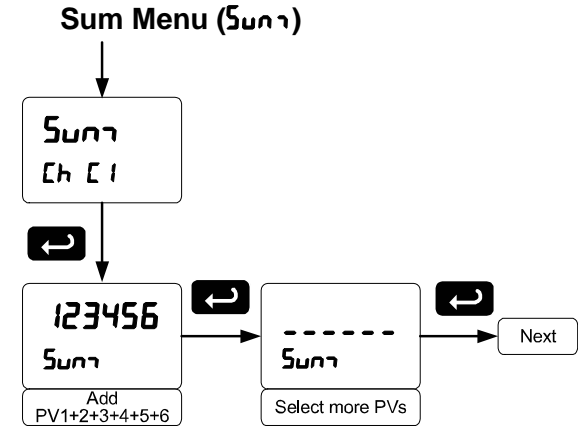

### Divide Menu (דifer טויער)

Only two PVs at a time will be used for this function.

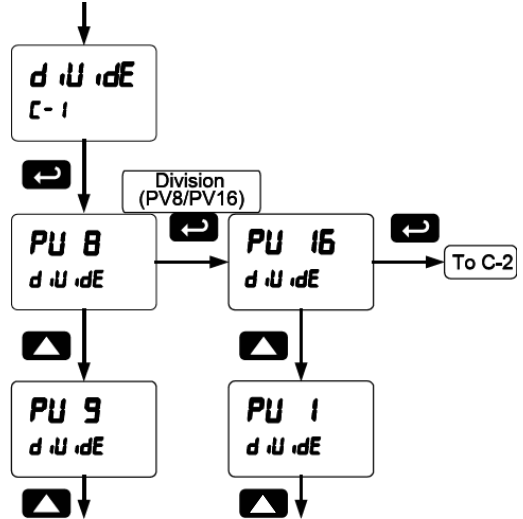

- Notes:
1. Press Up arrow to scroll through PV1 - PV16
  2. The first PV is the dividend and the second PV is the divisor.

### Maximum PV Menu (H i-PU)

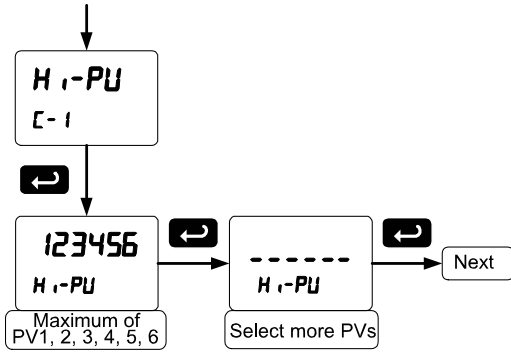

### Minimum PV Menu (Lo-PU)

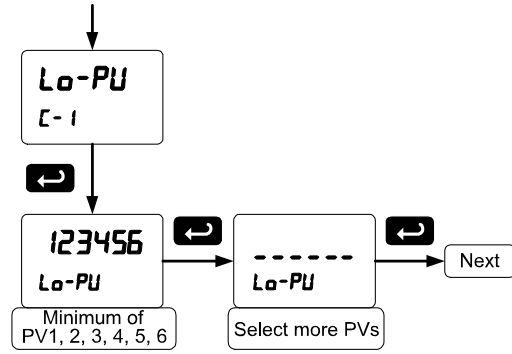

### Draw Menu (drRuu)

Only two PVs at a time will be used for this function.

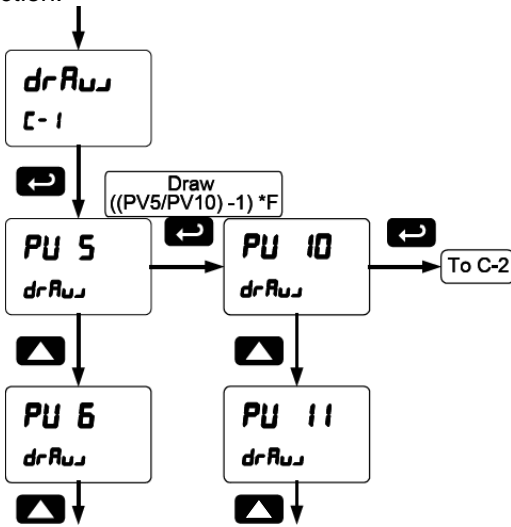

- Notes:
1. Press Up arrow to scroll through PV1 - PV16
  2. The first PV is the dividend and the second PV is the divisor.

### Weighted Average Menu (uuRUG)

Only two PVs at a time will be used for this function

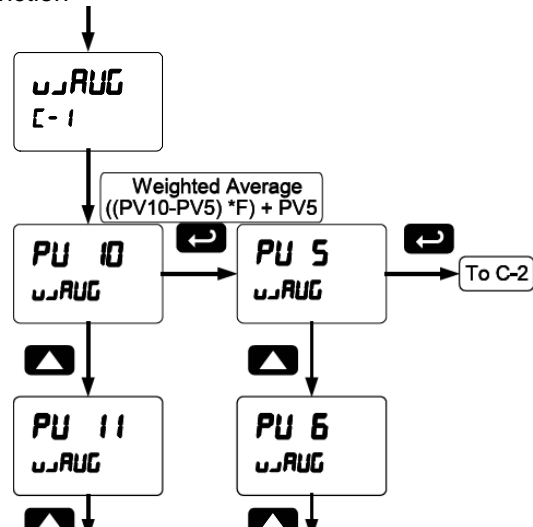

- Notes:
1. Press Up arrow to scroll through PV1 - PV16
  2. The first PV selected is the first PV in the equation.

### Ratio Menu (rRt io)

Only two PVs at a time will be used for this function

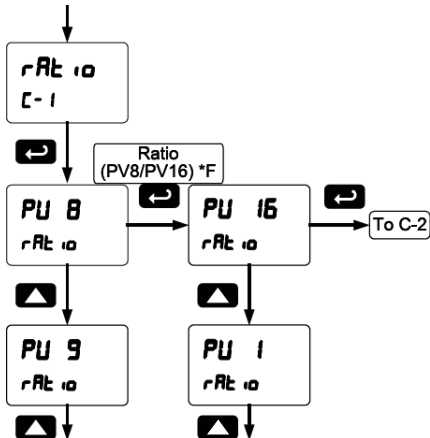

- Notes:
1. Press Up arrow to scroll through PV1 - PV16
  2. The first PV is the dividend and the second PV is the divisor.

### Concentration Menu (ConcEn)

Only two PVs at a time will be used for this function

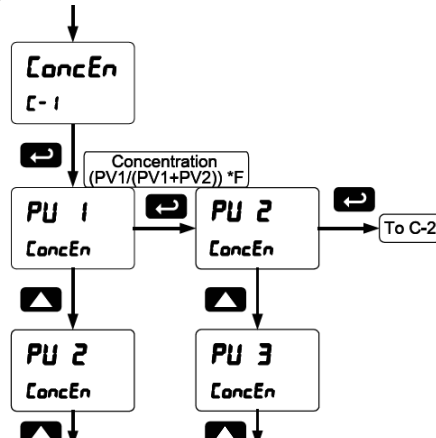

- Notes:
1. Press Up arrow to scroll through PV1 - PV16
  2. The first PV is the dividend and the Sum of the PVs is the divisor.

### Low-Flow Cutoff (Cutoff)

The low-flow cutoff feature allows the scanner to be programmed so that the often unsteady output from a differential pressure transmitter, at low flow rates, always displays zero on the scanner. The cutoff value may be programmed from 0 to 999999. When the input data is below the cutoff value, the scanner will display zero. Programming the cutoff value to zero disables the cutoff feature.

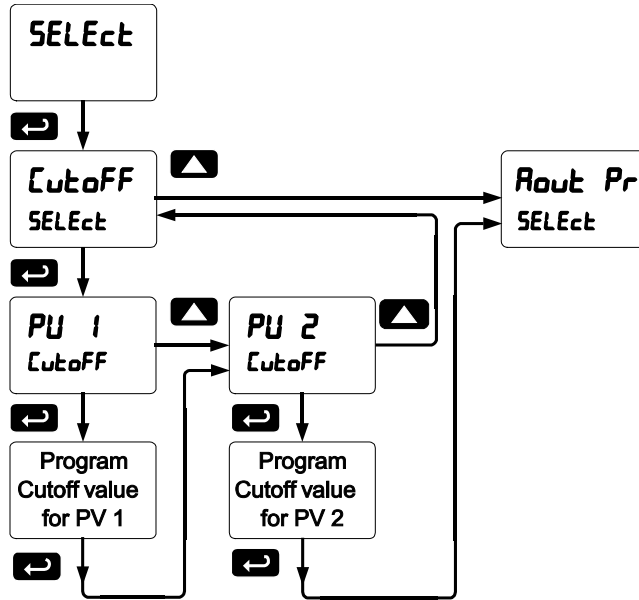

### Analog Output Source Programming (RoutPr)

The 4-20 mA analog outputs can be programmed for source of data, overrange and underrange, absolute maximum and minimum output, and communications break values. They can also be recalibrated.

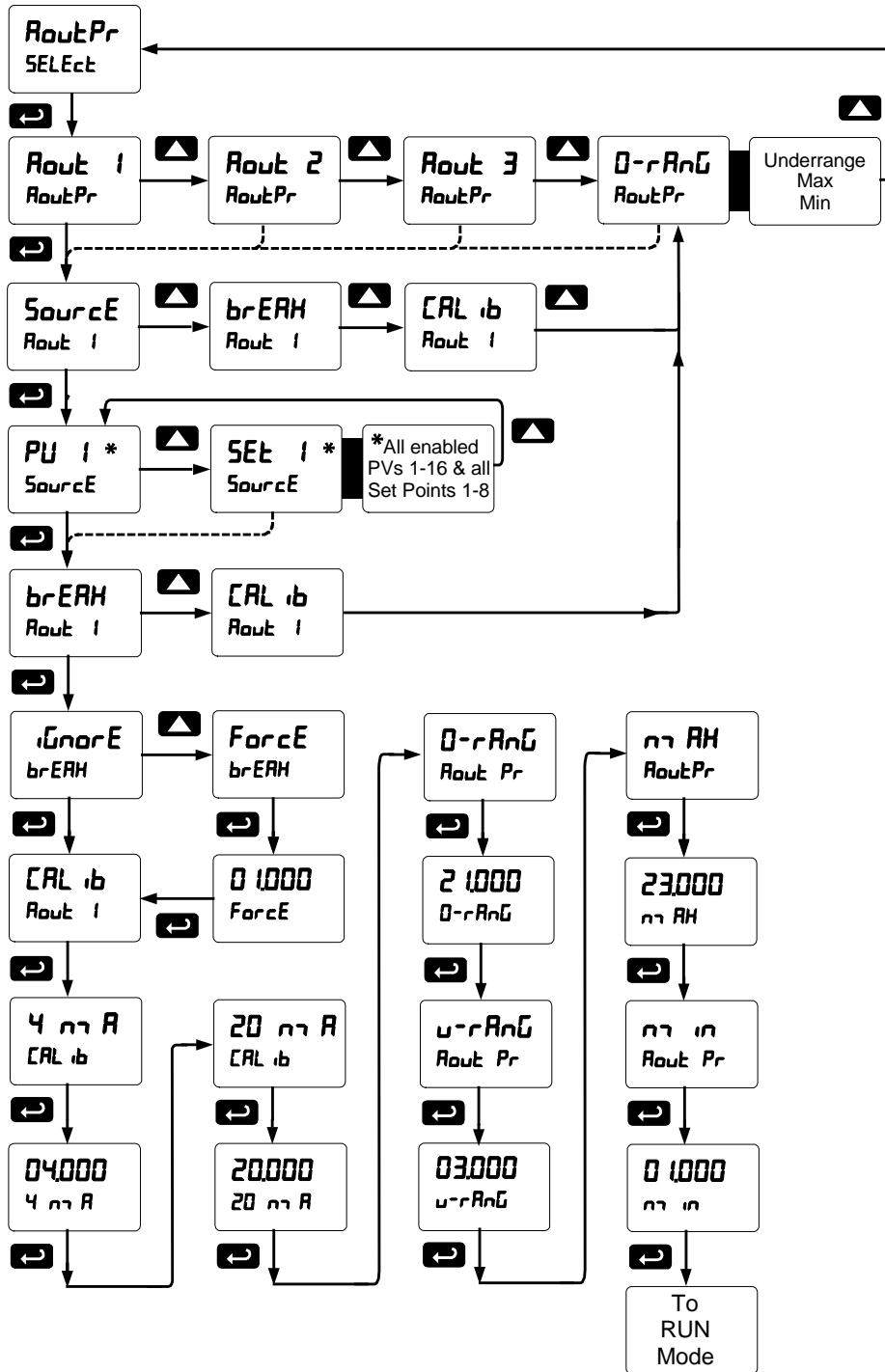

- To calibrate the analog outputs, follow the graphic above while measuring the mA output signal.
- The overrange and underrange values are the values that will be output when the display shows an overrange or underrange condition. This setting is common to all analog outputs.
- The maximum and minimum values are the absolute limits for the 4-20 mA output. This setting is common to all analog outputs.
- The communications break value determines the mA output when a Slave fails to reply to a command within the Response time.



### User Menu (uSEr)

The *User* menu allows the user to assign the front panel function keys F1, F2, and F3, the digital input F4 (a digital input located on the signal input connector), and up to eight additional digital inputs to access most of the menus or to activate certain functions immediately (e.g. reset max & min, hold relay states, etc.). This allows the meter to be greatly customized for use in specialized applications.

Up to eight digital outputs can be assigned to a number of actions and functions executed by the meter (i.e. alarms, relay acknowledgement, reset max, min, or max & min, tare, and reset tare). The digital outputs can be used to trigger external alarms or lights to indicate these specific events.

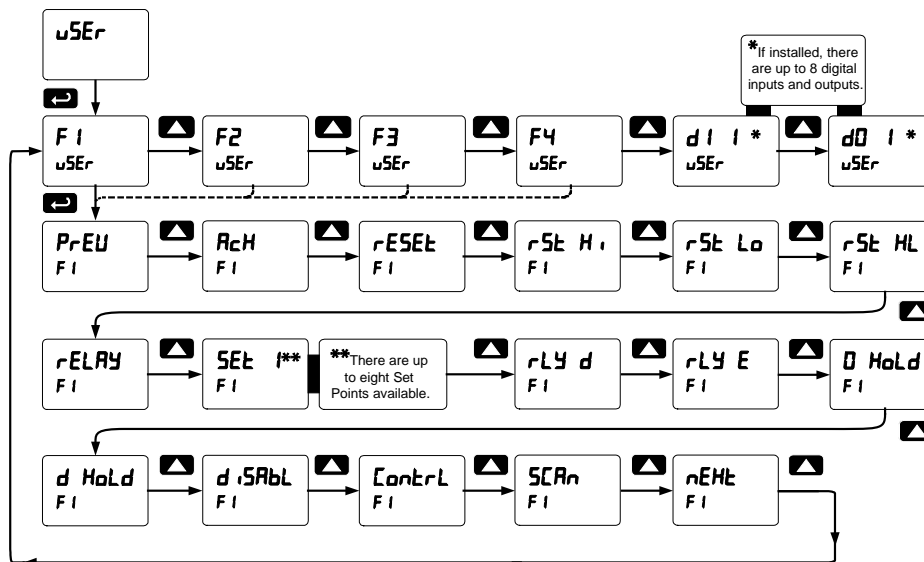

### Function Keys & Digital I/O Available Settings

Display	Description
SCAn	Scan PVs
nEHt	Next PV
PrEU	Previous PV
Rch	Acknowledge all active relays that are in a manual operation mode such as auto-manual or latching
rESEt	Directly access the reset menu
rSt H i	Reset the stored maximum display values for all channels
rSt Lo	Reset the stored minimum display values for all channels
rSt Hl	Reset the stored maximum & minimum display values for all channels
rELAY	Directly access the relay menu
SEt i*	Directly access the set point menu for relay 1 (*through 8)
rLY d	Disable all relays until a button assigned to <i>enable relays (rLY E)</i> is pressed
rLY E	Enable all relays to function as they have been programmed
D HoLd	Hold current relay states and analog output as they are until a button assigned to <i>enable relays (rLY E)</i> is pressed

Display	Description
d HoLd	Hold the current display value, relay states, and analog output momentarily while the function key or digital input is active. The process value will continue to be calculated in the background.
d iSAbL	Disable the selected function key or digital I/O
Contrl	Directly access the control menu
nEHt	Mimic the menu button functionality (digital inputs only)
r iSht	Mimic the right arrow/F1 button functionality (digital inputs only)
uP	Mimic the up arrow/F2 button functionality (digital inputs only)
EnEtEr	Mimic the enter/F3 button functionality (digital inputs only)
F on i*	Force relay 1 (*through 4) into the on state. This function is used in conjunction with a digital input expansion module to achieve interlock functionality. See page 48 for details about interlock relays.
RLnk i*	Provide indication when alarm 1 (*through 8) has been triggered (digital outputs only)

### Digital Input Menu (d I I)

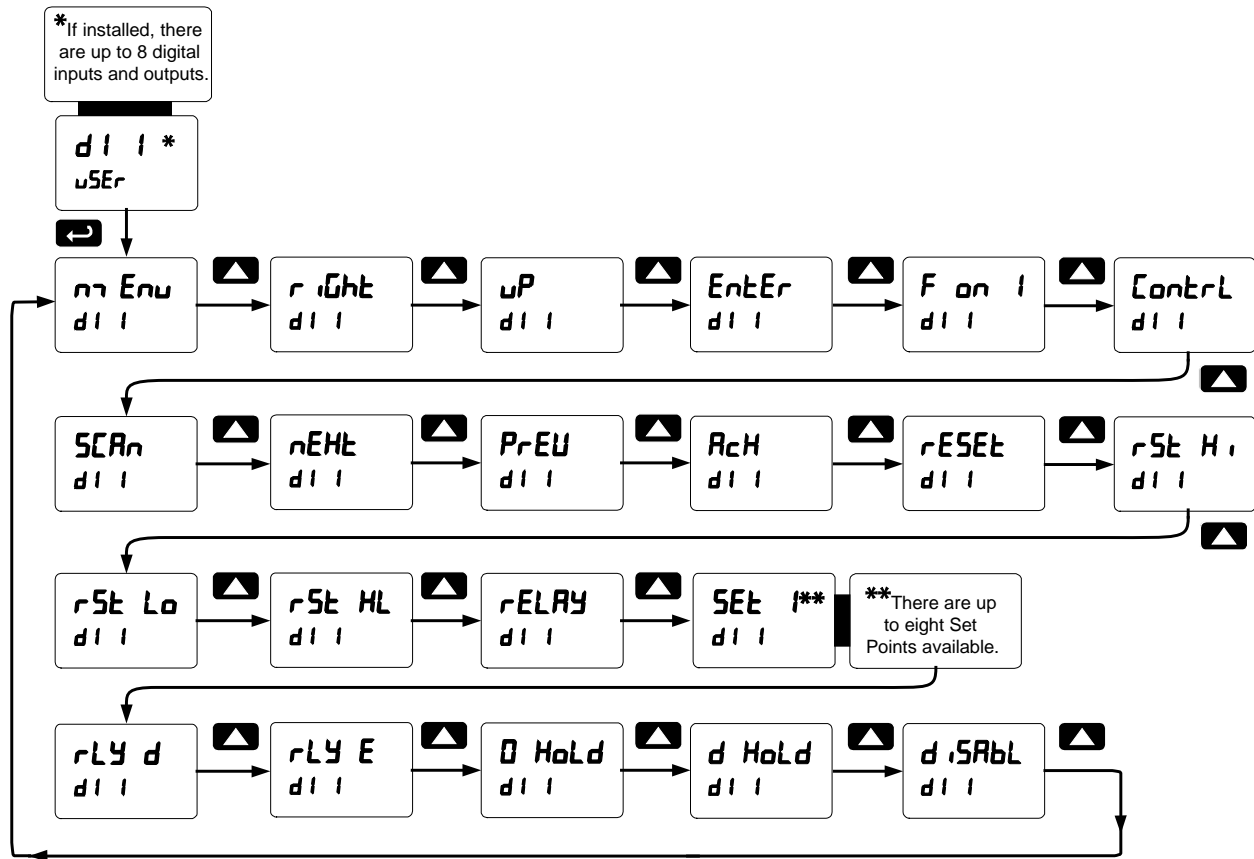

### Digital Output Menu (d O I)

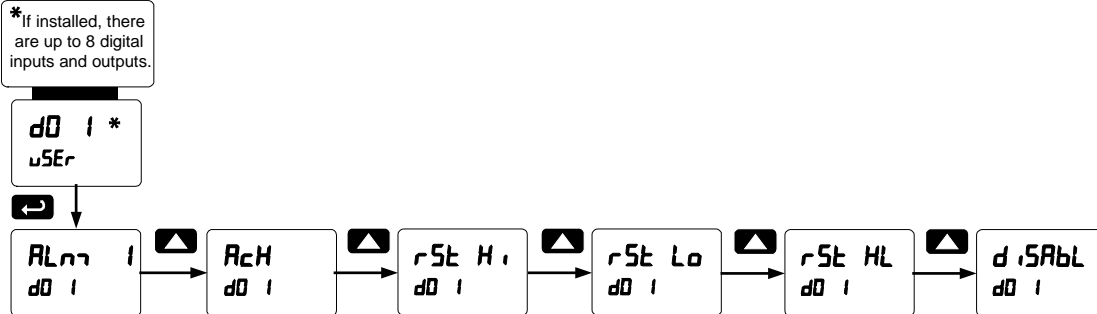

### Reset Function (reset)

The *Reset* function is used to reset the maximum or minimum reading (peak or valley) reached by the process; both may be reset at the same time by selecting “reset high & low” (*rSt HL*). This is applied to all PVs and math channels.

Resetting is possible by going into the USER menu, selecting a function key or digital input, pressing ENTER to take you to the next level, then pressing the Up arrow until you arrive at the RESET menu. Press ENTER to assign the RESET function to the selected function key or digital input. Now, when the scanner is in Run Mode, pressing the selected function key will take you to the RESET function, where you can scroll through Reset Hi (Max), Reset Lo (Min), and Reset HiLo (Reset Max and Min), choosing what value to reset. You can also select the specific reset function (e.g. Reset HiLo) to the selected digital input or function key.

## 4-20 mA Output Calibration

- There is **no need to recalibrate** the 4-20 mA output when first received from the factory.
- The 4-20 mA outputs is **factory calibrated** prior to shipment. The calibration equipment is certified to NIST standards.

The 4-20 mA output can be recalibrated in the field. A calibrated digital meter with an input range of at least 25 mA and a resolution of 1  $\mu$ A is recommended.



### CAUTION!

*If an uncalibrated meter or a meter with less resolution is used, the calibration of the 4-20 mA output could be adversely affected.*

## 4-20 mA Output Calibration Procedure

1. Wire the DPM-100 4-20 mA output to a current loop that includes a power supply (internal or external 12 to 24 VDC), and the mA input on the digital meter. See page 17 for details.
2. Turn on all devices. Allow for a 15 to 30 minute warm-up.
3. Go to the Advanced Features menu, and navigate to the Analog Output Programming (**ANAL OUT**)/Calibration (**CALIB**) menu and press **Enter**.
4. The display will show **4 mA**. The DPM-100 mA output should now be close to 4 mA. Press **Enter** and the display will show **04.000**. Enter the actual value read by the digital mA meter and press **Enter**.
5. The display will show **20 mA**. The DPM-100 mA output should now be close to 20 mA. Press **Enter** and the display will show **20.000**. Enter the actual value read by the digital mA meter and press **Enter**.
6. The DPM-100 will now calculate the calibration factors and store them.
7. Press Menu to exit and return to Run mode.

## Troubleshooting

Due to the many features and functions of the scanner, it's possible that the setup of the scanner does not agree with what an operator expects to see. If the scanner is not working as expected, refer to the recommendations below.

Symptom	Check/Action
No display at all	Check power at power connector
Not able to change setup or programming, <b>Locd</b> is displayed	Scanner is password-protected, enter correct six-digit password to unlock
Scanner displays error message during scaling ( <b>Error</b> )	Check: Input 2 must be greater than Input 1, Input 3 must be greater than Input 2, etc.
Scanner displays 1. 999999 2. -999999	Indicating overrange or underrange condition Check the input data value and scaling in <i>Setup</i> menu
Display stop scanning, ■LED indicator flashing	Check: 1. Stop on alarm feature has been enabled 2. Press PREV or NEXT to resume scanning
Displays <b>brERRH</b> message	Check: 1. RS-485 connection to slave devices 2. Slave Id, register number of slave devices 3. Baud rate and parity of all devices on the bus 4. Scanner Id must be different from other devices
Snooper mode not reading the PVs on the RS-485 bus	Check: 1. Increase Master's Transmit Delay (e.g. Snooper delay = 100ms, Master delay = 110ms) 2. Increase Snooper's byte-to-byte timeout 3. Decrease the slave device's transmit delay to <10ms 4. Snooper cannot read the same PV twice, check setup
Scanner experiencing faults and communication breaks	Check: Increase response time ( <b>trESP</b> ) and/or transmit delay ( <b>tr dLY</b> ). This may require some trial and error, as these are dependent upon the number of devices on the bus.
Scanner not communicating with ScanView software	Check: 1. Serial adapter and cable 2. Serial settings 3. Scanner address, baud rate, and transmit delay
Display does not respond to input data, reading a fixed number	Check: Display assignment, it might be displaying max/ min
Display reading is not accurate	Check: 1. PV Scaling 2. Check format selected: dec or ft&in
Relay operation is reversed	Check: 1. Fail-safe in <i>Setup</i> menu 2. Wiring of relay contacts
Relay and status LED do not respond to signal	Check: 1. Relay action in <i>Setup</i> menu 2. Set and reset points
Flashing relay status LEDs	Relays in manual control mode or relay interlock switches opened.
If the display locks up or the scanner does not respond at all	Cycle the power to reboot the microprocessor.
Other symptoms not described above	Call Technical Support for assistance.

## Diagnostics Menu (d iRG)

The *Diagnostics* menu is located in the *Advanced Features* menu, to access *Diagnostics* menu see page 51. This menu allows the user to test the functionality of all the meter LEDs, check the meter's software and version information, and erase the MeterView Pro software installation files from the meter. Press the Enter button to view the settings and the Menu button to exit at any time.

### Determining Software Version

To determine the software version of a scanner:

1. Go to the *Diagnostics* menu (d iRG) and press Enter button.
2. Press Up arrow button and scroll to Information menu ( iNFo).
3. Press Enter to access the software number (SFt) and version (UEr) information. Write down the information as it is displayed. Continue pressing Enter until all the information is displayed.
4. The scanner returns to Run Mode after displaying all the settings.

### Reset Scanner to Factory Defaults

When the parameters have been changed in a way that is difficult to determine what's happening, it might be better to start the setup process from the factory defaults.

#### Instructions to load factory defaults:

1. Enter the *Advanced Features* menu, see page 51.
2. Press Up arrow to go to *Diagnostics* menu
3. Press and hold Right arrow for three seconds, press Enter when display flashes **rESEt**.  
*Note: If Enter is not pressed within three seconds, the display returns to Run Mode.*
4. The scanner goes through an initialization sequence (similar as on power-up), and loads the factory default settings.

### Testing the Display LEDs

Enter the Diagnostic menu and press the ENTER button to get to the LED Test menu (LEd t). Press the ENTER button to activate the LED Test. The DPM-100 will cycle through all digits, decimal points, and relay indicators to enable the operator to see that all are functioning properly. Press the ENTER button again to access the Information menu ( iNFo). Press the MENU button to return to Run Mode.

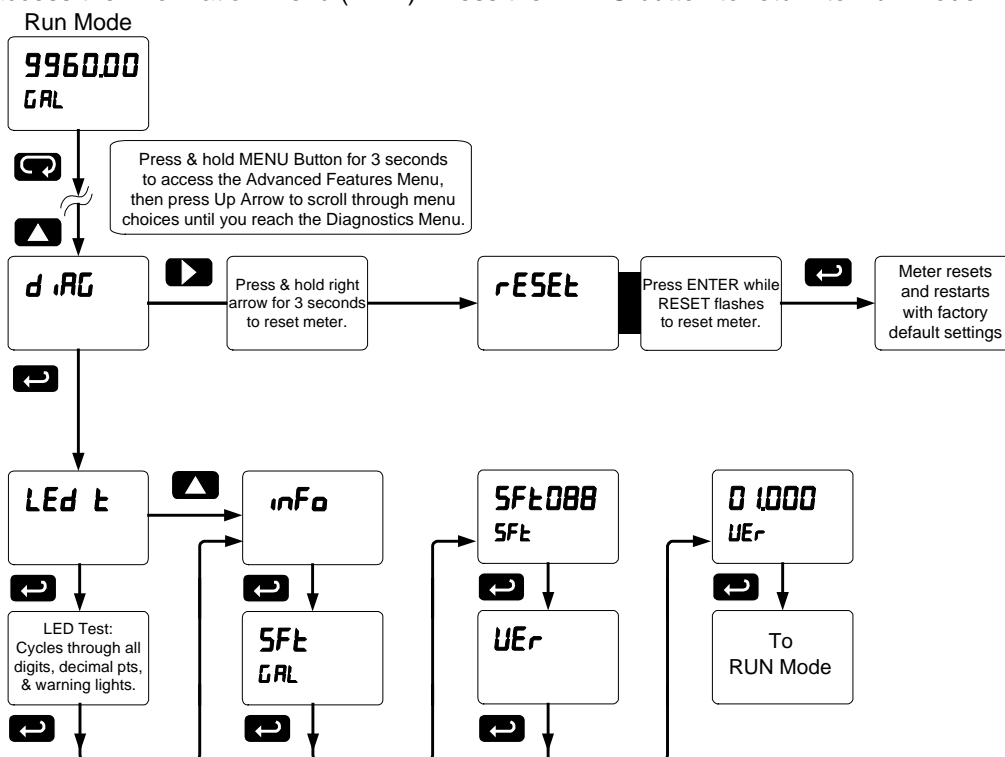

## Scanner Operation





The DPM-100 scanner is capable of operating as a Modbus Master, Slave or Snooper. As a Slave, the DPM-100 requires connection to a Master device: PLC, DCS, etc. As a Master, the DPM-100 interfaces up to sixteen slave devices and can alternately display their Process Variables. As a Snooper it can be connected anywhere in the RS-485 bus to read any of the variables being requested by the Master device.

Four math channels (C1-C4) are available to perform operations on any PV or math channel, with adder and factor constants, and display the results. Engineering units or tags may be displayed with all PVs or math channels. Another level of Math functions can be performed on the resultant math channel Math2. For example, the operator can use the Math2 Channel to calculate the Sum of all other Math Channels, which may have each performed a different Math function.

The dual-line display can be customized by the user. Typically, the upper display is used to display the PV, while the lower display is used to display the tag for each PV.

Additionally, the scanner can be set up to display any input or math channel on the upper display and alternate between tag & units on the lower display. The relays and analog output can be programmed to operate based on any PV or math channel.

## Front Panel Buttons Operation

Button Symbol	Description
	Press to enter, exit Programming Mode, or exit max/min readings
	Press to move to the previous PV or math channel
	Press to move to the next PV or math channel
	Press once to pause scanning, press again to resume scanning

## Function Keys Operation

During operation, the programmable function keys operate according to the way they have been programmed in the *Advanced Features – User* menu.

The table above shows the factory default settings for F1, F2, and F3.

## F4 Operation

A digital input, F4, is standard on the scanner. This digital input is programmed identically to function keys F1, F2, and F3. The input is triggered with a contact closure to COM, or with an active low signal. During operation, F4 operates according to the way it has been programmed in the *Advanced Features – User* menu. See page 65 for details.

## Maximum/Minimum Readings

The max & min readings (peak & valley) reached by the PVs or math channels can be displayed by assigning the display to max/min through the *Display Setup* menu.

A digital input should be programmed to reset the max & min readings.

## Factory Defaults & User Settings

The following table shows the factory setting for most of the programmable parameters on the DPM-100 scanner.

Parameter	Display	Default Setting
Mode	<i>Ma</i> <i>oDE</i>	Master
Function Code	<i>Fu</i> <i>nCo</i> <i>d</i>	03
PV Number	<i>PV</i> <i>nb</i> <i>r</i>	PV1-PV4 Enabled
Slave ID PV1-16	<i>SL</i> <i>AV</i> <i>id</i>	001 - 016
Register Number PV1-16	<i>rE</i> <i>Co</i> <i>nb</i> <i>r</i>	40001
Data Type PV1-16	<i>dR</i> <i>At</i> <i>A</i>	Float
Byte Order	<i>i234</i>	Big-endian
Polling Time	<i>t-P</i> <i>oLL</i>	5.0 second
Slave Response Timeout	<i>t-r</i> <i>ESP</i>	10.0 second
Serial	<i>SE</i> <i>r</i> <i>AL</i>	
Scanner ID	<i>SC</i> <i>AN</i> <i>id</i>	246
Baud	<i>bR</i> <i>ud</i>	9600
Parity	<i>PR</i> <i>r</i> <i>tY</i>	Even
Byte-to-byte timeout	<i>t-b</i> <i>y</i> <i>tE</i>	0.01 second
Setup	<i>SE</i> <i>t</i> <i>uP</i>	
Tag PV1-16	<i>t</i> <i>AG</i> <i>PU</i> <i>1</i>	PV 1 – PV 16
Units PV1-16	<i>Un</i> <i>tS</i> <i>PU</i> <i>1</i>	FEET
Units C1-4	<i>Un</i> <i>tS</i> <i>Ch</i> <i>C</i> <i>1</i>	UnitC1 – UnitC4
Display Format PV1-16	<i>For</i> <i>nt</i> <i>PU</i> <i>1</i>	Dec
Display Format C1-4	<i>For</i> <i>nt</i> <i>Ch</i> <i>C</i> <i>1</i>	Decimal
Display decimal point	<i>d</i> <i>SP</i> <i>dP</i>	ddd.ddd
Float decimal point	<i>FL</i> <i>ot</i> <i>dP</i>	ddd.ddd
Number of points	<i>no</i> <i>P</i> <i>tS</i>	2 (all PVs and C channels)
Scaling	<i>SCALE</i> <i>PU</i> <i>1</i>	All
Input 1	<i>inP</i> <i>1</i>	0.000
Display 1	<i>d</i> <i>S</i> <i>1</i>	0.000
Input 2	<i>inP</i> <i>2</i>	10.000
Display 2	<i>d</i> <i>S</i> <i>2</i>	10.000

Parameter	Display	Default Setting
Math, channel C1-4	<i>Su</i> <i>nn</i>	Sum
Adder (constant P)	<i>Ad</i> <i>dEr</i>	0.000
Factor (constant F)	<i>FA</i> <i>ct</i> <i>or</i>	1.000
Filter	<i>F</i> <i>IL</i> <i>tEr</i>	
Filter, PV 1	<i>PU</i> <i>1</i>	0
Filter, PV 2	<i>PU</i> <i>2</i>	0
Bypass, PV 1	<i>bY</i> <i>P</i> <i>ASS</i>	0.2
Bypass, PV 2	<i>bY</i> <i>P</i> <i>ASS</i>	0.2
Round	<i>r</i> <i>ou</i> <i>nd</i>	1
Cutoff	<i>C</i> <i>u</i> <i>t</i> <i>o</i> <i>FF</i>	
Cutoff value, PV 1	<i>PU</i> <i>1</i>	0.000 (disabled)
Cutoff value, PV 2	<i>PU</i> <i>2</i>	0.000 (disabled)
Display assignment	<i>d</i> <i>S</i> <i>P</i> <i>L</i> <i>A</i> <i>Y</i>	
Line 1	<i>d</i> <i>PU</i>	Display PV
Line 2	<i>d</i> <i>t</i> <i>AG</i>	Display tag
Display intensity	<i>d-</i> <i>in</i> <i>tY</i>	8
Relay 1 assignment	<i>PU</i> <i>1</i>	PV 1
Relay 1 action	<i>Ac</i> <i>t</i> <i>1</i>	Automatic
Relay 1 set point	<i>SE</i> <i>t</i> <i>1</i>	1.000
Relay 1 reset point	<i>r</i> <i>S</i> <i>t</i> <i>1</i>	0.500
Relay 2 assignment	<i>PU</i> <i>2</i>	PV 2
Relay 2 action	<i>Ac</i> <i>t</i> <i>2</i>	Automatic
Relay 2 set point	<i>SE</i> <i>t</i> <i>2</i>	2.000
Relay 2 reset point	<i>r</i> <i>S</i> <i>t</i> <i>2</i>	1.500
Relay 3 assignment	<i>PU</i> <i>3</i>	PV 3
Relay 3 action	<i>Ac</i> <i>t</i> <i>3</i>	Automatic
Relay 3 set point	<i>SE</i> <i>t</i> <i>3</i>	3.000
Relay 3 reset point	<i>r</i> <i>S</i> <i>t</i> <i>3</i>	2.500

Parameter	Display	Default Setting
Relay 4 assignment	PV 4	PV 4
Relay 4 action	Act 4	Automatic
Relay 4 set point	SEt 4	4.000
Relay 4 reset point	rSEt 4	3.500
Fail-safe relay 1	FLS 1	Off
Fail-safe relay 2	FLS 2	Off
Fail-safe relay 3	FLS 3	Off
Fail-safe relay 4	FLS 4	Off
On delay relay 1	On 1	0.0 sec
Off delay relay 1	OFF 1	0.0 sec
On delay relay 2	On 2	0.0 sec
Off delay relay 2	OFF 2	0.0 sec
On delay relay 3	On 3	0.0 sec
Off delay relay 3	OFF 3	0.0 sec
On delay relay 4	On 4	0.0 sec
Off delay relay 4	OFF 4	0.0 sec
Comm. break relay 1	On	On
Comm. break relay 2	On	On
Comm. break relay 3	On	On
Comm. break relay 4	On	On
Display 1 analog out	d15 1	4.000
Output 1 value	Out 1	4.000 mA

Parameter	Display	Default Setting
Display 2 analog out	d15 2	20.000
Output 2 value	Out 2	20.000 mA
Source analog output	Source	PV 1
Overrange output	OverRnG	21.000 mA
Underrange output	u-rRnG	3.000 mA
Comm. break output	brERRH	1.000 mA
Maximum output	nrRH	23.000 mA
Minimum output	nrin	1.000 mA
F1 function key	F1	Previous PV
F2 function key	F2	Next PV
F3 function key	F3	Scan/Pause
F4 function (digital input)	F4	Acknowledge relays
Digital input 1	d1 1	Menu
Digital input 2	d1 2	Right arrow
Digital input 3	d1 3	Up arrow
Digital input 4	d1 4	Enter
Digital output 1	d0 1	Alarm 1
Digital output 2	d0 2	Alarm 2
Digital output 3	d0 3	Alarm 3
Digital output 4	d0 4	Alarm 4
Password 1	PASS 1	000000 (unlocked)
Password 2	PASS 2	000000 (unlocked)
Password 3	PASS 3	000000 (unlocked)



*This Page Intentionally Left Blank*

